

Question no. 1

From a uniform circular disc of radius R and mass $9M$, a small disc of radius $\frac{R}{3}$ is removed as shown in the figure. The moment of inertia of the remaining disc about an axis perpendicular to the plane of the disc and passing through centre of disc is :

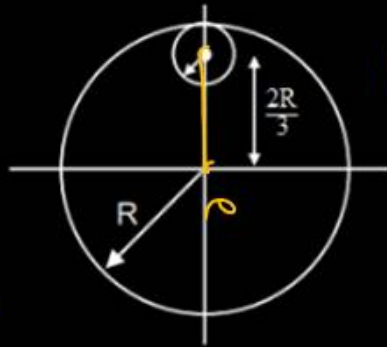

$$\pi R^2 \rightarrow 9M$$

$$\pi \left(\frac{R}{3}\right)^2 \rightarrow M$$

(1) $4 MR^2$

(2) $\frac{40}{9} MR^2$

(3) $10 MR^2$

(4) $\frac{37}{9} MR^2$

$$I_{\text{Disc}} = \frac{(9m)R^2}{2} \checkmark$$

$$\odot \rightarrow I_{\text{SD}} = \frac{M(R/3)^2}{2}$$

$$I_{\text{SDO}} = \frac{M(R/3)^2}{2} + M \left(2R/3\right)^2$$

$$= \frac{MR^2}{9} \left(\frac{1}{2} + 4\right) = \frac{MR^2}{2} \checkmark$$

$$I_0 = I_{\text{Disc}} - I_{\text{SDO}}$$

$$= \frac{9mR^2}{2} - \frac{mR^2}{2} = \frac{8mR^2}{2} = 4mR^2$$

Question no. 2

A grindstone has a moment of inertia of 6 kg-m^2 . A constant torque is applied and the grindstone is found to have a speed of 150 rpm , 10 seconds after starting from rest. The torque is

(1) $3\pi \text{ N-m}$

(2) 3 N-m

(3) $\frac{\pi}{3} \text{ N-m}$

(4) $4\pi \text{ N-m}$

①

$$I = 6 \text{ kg-m}^2$$

$$\omega_f = \omega_i + \alpha t$$

$$\cancel{150} \times \frac{2\pi}{\cancel{60}} = 0 + \left(\frac{\tau}{6}\right) 10$$

$$\frac{15 \times 2\pi}{\cancel{60} 10} = \frac{\tau}{6}$$

$$3\pi = \tau$$

Question no. 3

If the linear momentum is increased by 50%, then kinetic energy will be increased by

- (1) 50% (2) 100%
(3) 125% (4) 25%

3

$$K = \frac{P^2}{2m} \quad \checkmark$$

$$K_f = \frac{(P + P/2)^2}{2m} = \frac{9}{4} K$$

$$\therefore \uparrow = \frac{K_f - K}{K} \times 100 \%$$

$$= \left(\frac{\frac{9}{4}K - K}{K} \right) \times 100 \%$$

$$= \frac{5}{4} \times 100 \% = 125 \%$$

Question no. 4

A ball of mass m moving with a speed $2v_0$ collides head on with an identical ball at rest. If e is the coefficient of restitution, then what will be the ratio of velocity of two balls after collision? $\left(\frac{v_1}{v_2} = ?\right)$

(1) $\frac{1-e}{1+e}$

①

(2) $\frac{1+e}{1-e}$

(3) $\frac{e-1}{e+1}$

(4) $\frac{e+1}{e-1}$

$\frac{1-e}{1+e}$



$$2mv_0 + 0 = mv_1 + mv_2$$

$$v_1 + v_2 = 2v_0 \quad \text{--- (1)}$$

$$e = \frac{v_2 - v_1}{2v_0}$$

$$v_2 - v_1 = 2v_0 e \quad \text{--- (2)}$$

① + ②
 $2v_2 = 2v_0 e + 2v_0$
 $v_2 = v_0(1+e)$

$$v_1 = v_0(1-e)$$

Question no. 5

A particle acted upon by constant forces $4\hat{i} + \hat{j} - 3\hat{k}$ and $3\hat{i} + \hat{j} - \hat{k}$ is displaced from the point $\hat{i} + 2\hat{j} + 3\hat{k}$ to point $5\hat{i} + 4\hat{j} + \hat{k}$. The total work done by the forces in SI unit is

(1) 20

~~(2) 40~~

(3) 50

(4) 30

$$\vec{F}_N = 7\hat{i} + 2\hat{j} - 4\hat{k}$$

$$\vec{s} = 4\hat{i} + 2\hat{j} - 2\hat{k}$$

$$* W = \vec{F} \cdot \vec{s}$$

$$= 28 + \underline{4} + \underline{8}$$

$$= \underline{40 \text{ J}}$$

Question no. 6

The gravitational field strength at the surface of a certain planet is g . Which of the following is the gravitational field strength at the surface of a planet with twice the radius and twice the mass?

(1) $g/2$

(2) g

(3) $2g$

(4) $4g$

$$g = \frac{GM}{R^2}$$

$$g_p = \frac{2 \times 2M}{(2R)^2} = \frac{g}{2}$$

Question no. 7

A particle of mass m is kept at rest at a height $3R$ from the surface of earth, where R is radius of earth and M is mass of earth. The minimum speed with which it should be projected, so that it does not return back, is (g is acceleration due to gravity on the surface of earth)

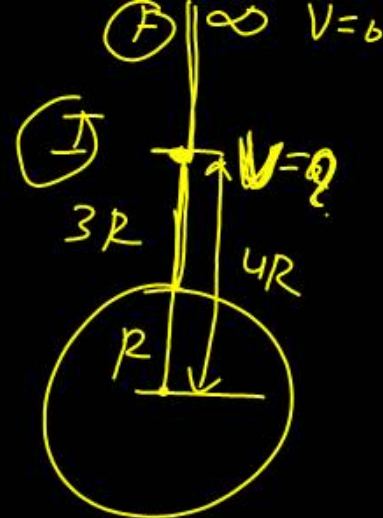

$$T_I = T_F$$

(1) $\left(\frac{GM}{2R}\right)^{1/2}$

(2) $\left(\frac{gR}{4}\right)^{1/2}$

$$\frac{1}{2} m v^2 - \frac{GMm}{4R} = 0 - 0$$

(3) $\left(\frac{2g}{R}\right)^{1/2}$

(4) $\left(\frac{GM}{R}\right)^{1/2}$

$$\frac{v^2}{2} = \frac{GM}{4R}$$

$$v = \sqrt{\frac{GM}{2R}}$$

Question no. 8

The radii of circular orbits of two satellites A and B of the earth, are $4R$ and R , respectively. If the speed of satellite A is $3v$, then the speed of satellite B will be

(1) $\frac{3v}{4}$

(2) $6v$

$$V_0 = \sqrt{\frac{GM}{r}}$$

(3) $12v$

(4) $\frac{3v}{2}$

$$\frac{V_A}{V_B} = \sqrt{\frac{r_B}{r_A}}$$

$$\frac{3v}{V_B} = \sqrt{\frac{R}{4R}} = \frac{1}{2}$$

$V_B = 6v$

Question no. 9

A capacitor of capacitance C_1 is charged to a potential V and then connected in parallel to an uncharged capacitor of capacitance C_2 . The final potential difference across each capacitor will be

~~(1)~~ $\frac{C_1 V}{C_1 + C_2}$

(2) $\frac{C_2 V}{C_1 + C_2}$

(3) $1 + \frac{C_2}{C_1}$

(4) $1 - \frac{C_2}{C_1}$

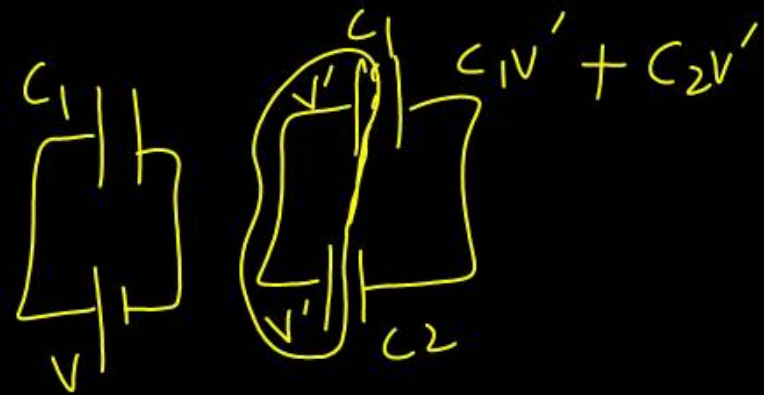

$Q = C_1 V$
initial charge

$C_1 V = C_1 V' + C_2 V'$
 $C_1 V = V' (C_1 + C_2)$
 $\frac{C_1 V}{C_1 + C_2} = V'$

Question no. 10

Two solenoids of equal number of turns have their lengths and the radii in same ratio 1:2. The ratio of their self-inductances will be

- ~~(1)~~ 1 : 2
(3) 1 : 1

- (2) 2 : 1
(4) 1 : 4

$$L \propto \frac{N^2 r^2}{l}$$

$$L_1 = \frac{N_1^2 r_1^2}{l_1}$$

$$L_2 = \frac{N_2^2 r_2^2}{l_2}$$

$$L = \frac{\mu_0 N^2 A}{l} = \frac{\mu_0 N^2 \pi r^2}{l}$$

$$\frac{l_1}{l_2} = \left(\frac{N_1 r_1^2}{N_2 r_2^2} \right) \times \frac{l_2}{l_1} = \left(\frac{1}{2} \right)^2 \times \frac{2}{1} = \left(\frac{1}{2} \right)$$

Question no. 11

The circuit is equivalent to

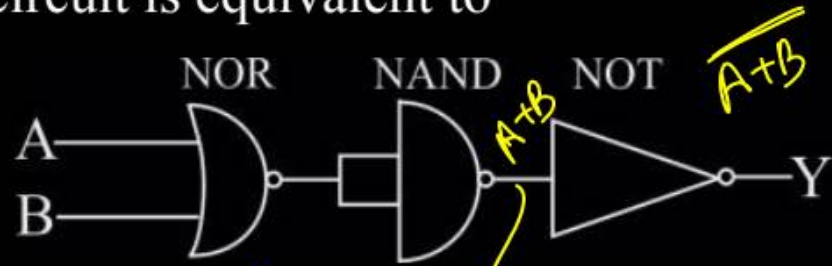

(1) AND gate

~~(3) NOR gate~~

(2) NAND gate

(4) OR gate

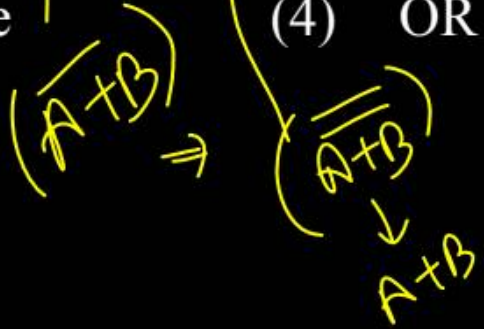

Question no. 12

Find the maximum radius of circle, so that the block can complete the circular motion.

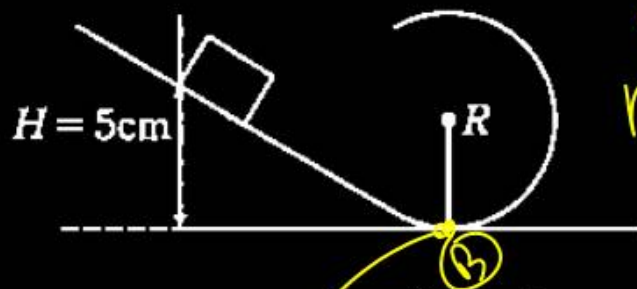

(1) 5 cm

(2) 3 cm

~~(3) 2 cm~~

(4) 4 cm

$\sqrt{5gR}$

$\downarrow \text{PE} = \text{KE}$
 $mgh = \frac{1}{2}mv^2$
 $v^2 = \sqrt{2gh}$
 $\sqrt{2gh} = \sqrt{5gR}$
 $2gh = 5gR$
 $R = \frac{2H}{5}$

Question no. 13

Solid spherical ball is rolling on frictionless horizontal plane surface about its axis of symmetry. The ratio of rotational kinetic energy of the ball to its total kinetic energy is :

(1) $\frac{2}{5}$

(2) $\frac{2}{7}$

(3) $\frac{1}{5}$

(4) $\frac{7}{10}$

2

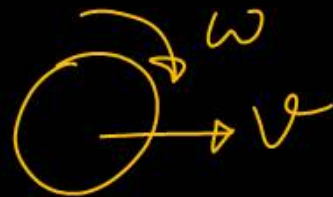

$$RKE = \frac{1}{2} I (v/R)^2$$

$$= \frac{1}{2} \times \frac{2}{5} MR^2 \times \frac{v^2}{R^2}$$

$$RKE = \frac{2}{5} \left(\frac{1}{2} MV^2 \right) \rightarrow TKE$$

$$TKE = \frac{1}{2} MV^2 \quad RKE = \frac{2}{5} (TKE)$$

$$\frac{RKE}{TKE} = \frac{RKE}{RKE + \frac{5}{2} RKE} = \frac{2}{7}$$

Question no. 14

A person, with outstretched arms, is spinning on a rotating stool. He suddenly brings his arms down to his sides. Which of the following is true about his kinetic energy K and angular momentum L ?

- (1) Both K and L increase
- (2) Both K and L remain unchanged
- (3) K remains constant, L increases
- (4) K increases but L remains constant

4



$Z_{ext} = 0$ ✓

$L \rightarrow$ conserved

$$L = I\omega \uparrow$$

$K \uparrow$

Question no. 15

A particle moves along the X-axis from $x = 0$ to $x = 5$ m under the influence of a force given by $F = 10 - 2x + 3x^2$. Work done in the process is

- (1) 70 units (2) 270 units
 (3) 35 units (4) 150 units

4

$$W = \int F dx$$

$$W = \int_0^5 (10 - 2x + 3x^2) dx$$

$$W = (10x - x^2 + x^3) \Big|_0^5$$

$$W = (50 - 25 + 125) - (0 + 0 + 0)$$

$$W = 150 \text{ J}$$

Question no. 16

A spherical ball A of mass 4 kg, moving along a straight line strikes another spherical ball B of mass 1 kg at rest. After the collision, A and B move with velocities v_1 m s⁻¹ and v_2 m s⁻¹ respectively making angles of 30° and 60° with respect to the original

direction of motion of A. The ratio $\frac{v_1}{v_2}$ will be

(1) $\frac{\sqrt{3}}{4}$

1

(2)

$\frac{4}{\sqrt{3}}$

$\frac{v_1}{v_2} = \frac{\sqrt{3}}{1}$

(3)

$\frac{1}{\sqrt{3}}$

(4)

$\sqrt{3}$

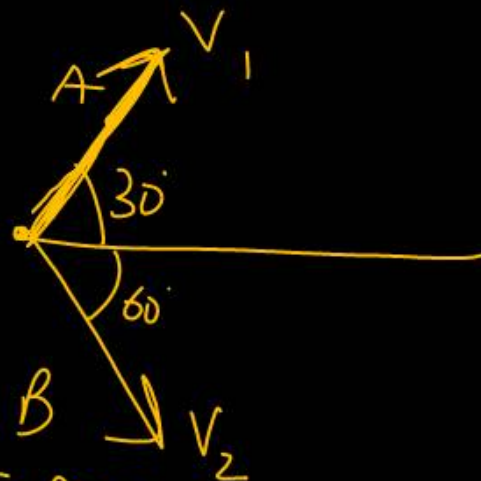
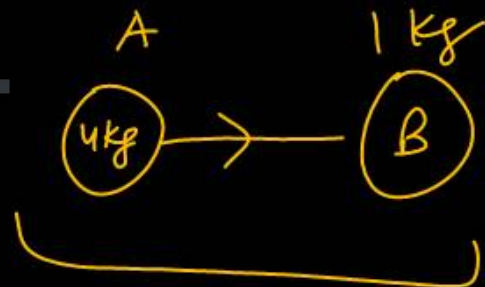

$m_A v_1 \sin 30^\circ = m_B v_2 \sin 60^\circ$
 $2v_1 = \frac{\sqrt{3}}{2}v_2$

Question no. 17

A block of mass m is moving with a speed v on a horizontal surface and collides with a horizontally mounted spring of spring constant k as shown in the figure. The coefficient of friction between the block and the floor is μ . The maximum compression of the spring is

(Floor upto spring is smooth then after it's rough)

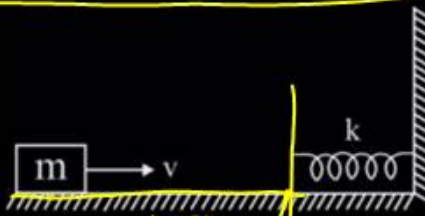

- (1) $\frac{\mu mg}{k} + \frac{1}{k} \sqrt{(\mu mg)^2 + mkv^2}$
- (2) $\frac{\mu mg}{k} + \frac{1}{k} \sqrt{(\mu mg)^2 - mkv^2}$
- (3) $-\frac{\mu mg}{k} - \frac{1}{k} \sqrt{(\mu mg)^2 - mkv^2}$
- (4) $\frac{\mu mg}{k} + \frac{1}{k} \sqrt{(\mu mg)^2 + mkv^2}$

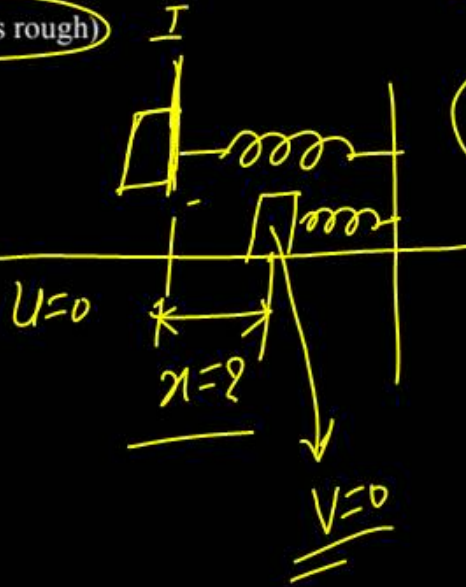

$$\frac{1}{2}mv^2 = \frac{1}{2}kx^2 + W_f$$

$$\frac{1}{2}mv^2 = \frac{1}{2}kx^2 + \mu mg \times x \quad ax^2 + bx + c = 0$$

$$\left(\frac{kx^2}{2}\right) + (\mu mgx) - \left(\frac{mv^2}{2}\right) = 0$$

$$x = \frac{-\mu mg + \sqrt{(\mu mg)^2 + 4 \times \frac{k}{2} \times \frac{mv^2}{2}}}{\frac{k}{2} - \frac{k}{2}}$$

$$x = \frac{-\mu mg}{\frac{k}{2}} + \frac{1}{\frac{k}{2}} \sqrt{(\mu mg)^2 + kmv^2}$$

Question no. 18

The height at which the weight of a body becomes $\left(\frac{1}{16}\right)^{\text{th}}$, its weight on the surface of earth (radius R), is

(1) 5R

(2) 15R

(3) 3R

(4) 4R

$$W = mg$$

$$h = R$$

$$g_h = \frac{g}{16}$$

$$g_h = \frac{g}{\left(1 + \frac{h}{R}\right)^2}$$

$$\frac{g}{16} = \frac{g}{\left(1 + \frac{h}{R}\right)^2}$$

$$\frac{1}{4} = \frac{1}{1 + \frac{h}{R}} \quad \left| \quad 1 + \frac{h}{R} = 4 \right.$$

$$\frac{h}{R} = 3$$

$$h = 3R$$

The relation between escape velocity (v_e) from the surface of the earth and the orbital velocity (v_o) is

(orbit neraby earth surface)

(1) $\sqrt{2}v_e = v_o$

(2) $v_e = \sqrt{2}v_o$

(3) $v_e = 2v_o$

(4) $4v_e = 3v_o$

$$v_e = \sqrt{\frac{2GM}{R}}$$

$$v_o = \sqrt{\frac{GM}{R}}$$

$$v_e = \sqrt{2} v_o$$

Question no. 20

An electron of mass m and charge q is accelerated from rest in a uniform electric field of strength E . The velocity acquired by it as it distance l is

(1) $\sqrt{\frac{2Eq l}{m}}$

(2) $\sqrt{\frac{2Eq}{ml}}$

(3) $\sqrt{\frac{2Em}{ql}}$

(4) $\sqrt{\frac{Eq}{ml}}$

$$u = 0$$

$$F = ma = qE$$

$$a = \frac{qE}{m}$$

$$s = l$$

$$V^2 = u^2 + 2as$$

$$V^2 = 0 + 2 \times \frac{qE}{m} \times l$$

$$V = \sqrt{\frac{2qEl}{m}}$$

Question no. 21

See the electrical circuit shown in this figure. Which of the following equations is a correct equation for it?

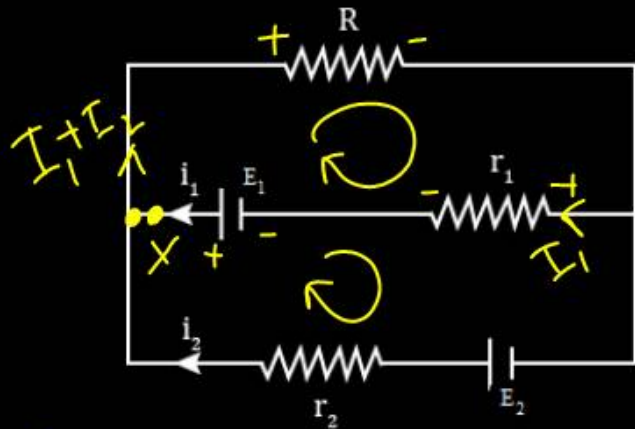

~~$-(I_1 + I_2)R - I_1 r_1 + E_1 = 0$~~
 ~~$E_1 = I_1 r_1 + (I_1 + I_2)R$~~

- (1) $E_1 - (i_1 + i_2)R - i_1 r_1 = 0$
- (2) $E_2 - i_2 r_2 - E_1 - i_1 r_1 = 0$
- (3) $-E_2 - (i_1 + i_2)R + i_2 r_2 = 0$
- (4) $E_1 - (i_1 + i_2)R + i_1 r_1 = 0$

Which of the following waves has the maximum wavelength?

- (1) X-rays (2) Infrared rays
(3) Ultraviolet rays (4) Radio waves

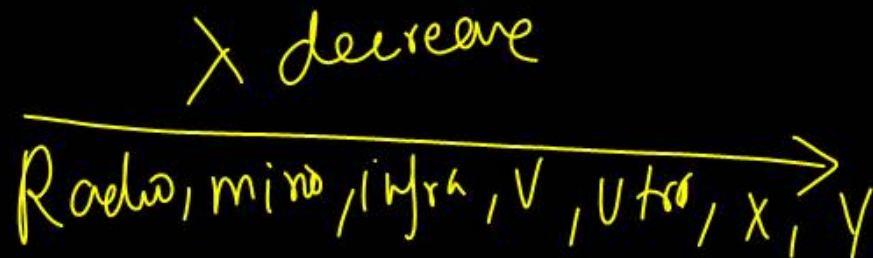

Question no. 23

Two particles of equal masses are revolving in circular paths of radii r_1 and r_2 respectively with the same speed. The ratio of their centripetal forces is

~~(1)~~ $\frac{r_2}{r_1}$

(2) $\sqrt{\frac{r_2}{r_1}}$

(3) $\left(\frac{r_1}{r_2}\right)^2$

(4) $\left(\frac{r_2}{r_1}\right)^2$

$f = m r \omega^2$
 $f_1 = m r_1 \omega^2$
 $f_2 = m r_2 \omega^2$

Question no. 24

Match List-I with List-II.

	List-I		List-II
A.	Moment of inertia of solid sphere of radius R about any tangent	i.	$\frac{5}{3}MR^2$
B.	Moment of inertia of hollow sphere of radius R about any tangent	ii.	$\frac{7}{5}MR^2$
C.	Moment of inertia of circular ring of radius R about its diameter.	iii.	$\frac{1}{4}MR^2$
D.	Moment of inertia of circular disc of radius R about any diameter	iv.	$\frac{1}{2}MR^2$

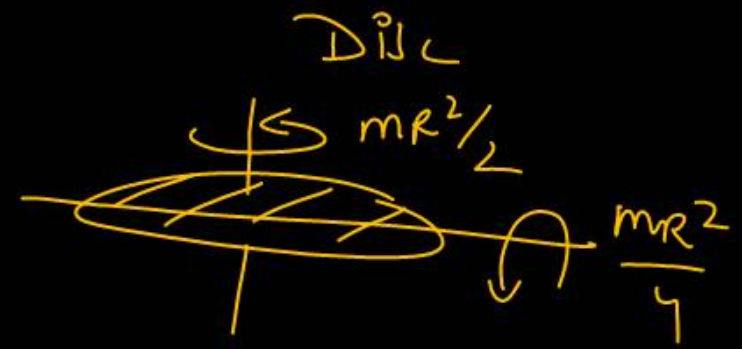
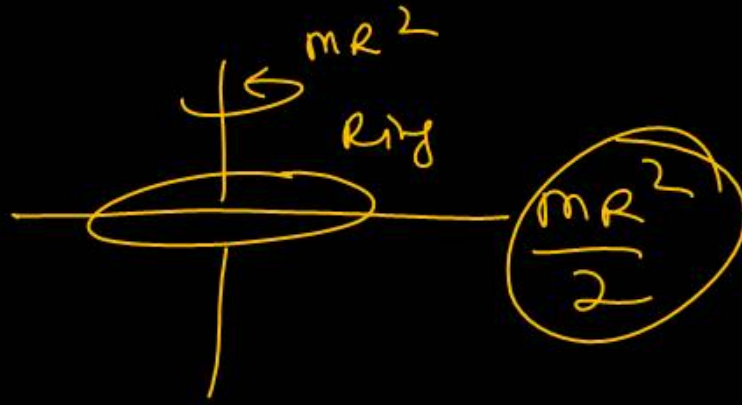

A \rightarrow (ii)
 B \rightarrow (i)
 C \rightarrow (iv)
 D \rightarrow (iii)

Choose the correct answer from the options given below :

- (1) A - ii, B - i, C - iv, D - iii
- (2) A - i, B - ii, C - iv, D - iii
- (3) A - ii, B - i, C - iii, D - iv
- (4) A - i, B - ii, C - iii, D - iv

1

Question no. 25

Two particles of mass 1 kg and 3 kg have position vectors $2\hat{i}+3\hat{j}+4\hat{k}$ and $-2\hat{i}+3\hat{j}-4\hat{k}$ respectively.

The centre of mass has a position vector

- (1) $\hat{i}+3\hat{j}-2\hat{k}$ (2) $-\hat{i}-3\hat{j}-2\hat{k}$
 (3) $-\hat{i}+3\hat{j}+2\hat{k}$ (4) $-\hat{i}+3\hat{j}-2\hat{k}$

4

$$\vec{r}_{\text{com}} = \frac{m_1 \vec{r}_1 + m_2 \vec{r}_2}{m_1 + m_2}$$

$$= \frac{1(2\hat{i}+3\hat{j}+4\hat{k}) + 3(-2\hat{i}+3\hat{j}-4\hat{k})}{4}$$

$$= \frac{-4\hat{i}+12\hat{j}-8\hat{k}}{4}$$

$$\vec{r}_{\text{com}} = -\hat{i}+3\hat{j}-2\hat{k}$$

Question no. 26

Force constants of two wires A and B of the same material and k and $2k$, respectively. If the two wires are stretched equally, then the ratio of work done in

stretching $\left(\frac{W_A}{W_B}\right)$ is

(1) $\frac{1}{3}$

(2)

(2) $\frac{1}{2}$

(3) $\frac{3}{2}$

(4) $\frac{1}{4}$

$$\frac{W_A}{W_B} = \frac{\frac{1}{2} k x^2}{\frac{1}{2} (2k) x^2} = \frac{1}{2}$$

During inelastic collision between two bodies, which of the following quantities always remain conserved?

- (1) total kinetic energy
- (2) Total mechanical energy
- (3) Total linear momentum
- (4) Speed of each body

3

A bullet of mass m moving horizontally with a velocity v strikes a block of wood of mass M and gets embedded in the block. The block is suspended from the ceiling by a massless string. The height to which the block rises is

(1) $\frac{v^2}{2g} \left(\frac{m}{M+m} \right)^2$

(2) $\frac{v^2}{2g} \left(\frac{M+m}{m} \right)^2$

(3) $\frac{v^2}{2g} \left(\frac{m}{M} \right)^2$

(4) $\frac{v^2}{2g} \left(\frac{M}{m} \right)^2$

$$mV = (m+M)V_1$$

$$V_1 = \frac{mv}{(m+M)}$$

$$\frac{1}{2} \times (m+M) \times \left(\frac{mv}{(m+M)} \right)^2 = (m+M) \times gh$$

$$h = \frac{1}{2g} \times \frac{m^2 v^2}{(m+M)^2}$$

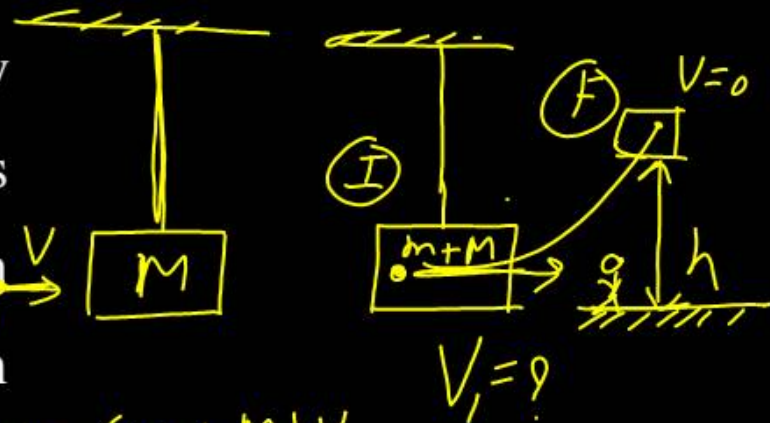

If a body of mass m has to be taken from the surface of earth to a height $h = R$ then the amount of energy required is (R : radius of earth)

(1) mgR

(2) $\frac{mgR}{3}$

(3) $\frac{mgR}{2}$

(4) $\frac{mgR}{12}$



$$U_I = -\frac{GmM}{R}$$

$$U_F = -\frac{G \times mM}{2R}$$

$$\Delta U = \frac{GmM}{2R} - \frac{GmM}{R}$$

$$\Delta U = \frac{mgR}{2}$$

The energy required to move a satellite of mass m from an orbit of radius $2R$ to $3R$ around earth to mass M is

(1) $\frac{GMm}{12R}$

(2) $\frac{GMm}{R}$

(3) $\frac{GMm}{8R}$

(4) $\frac{GMm}{2R}$

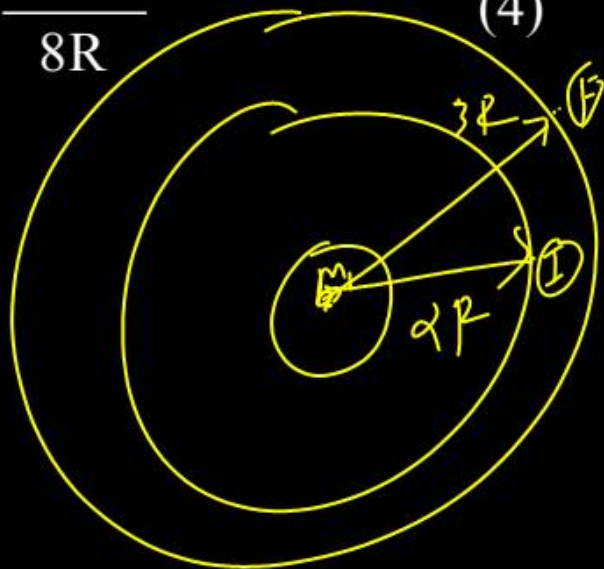

T.E. = $-\frac{GMm}{2R}$

$U_I = -\frac{GMm}{2R}$

$U_F = -\frac{GMm}{3R}$

$\Delta U = \frac{GMm}{12R}$

$$E = \frac{kQ}{R^2}$$

Figure below show regular hexagons, with charges at the vertices. In which case, is the electric field at the centre zero?

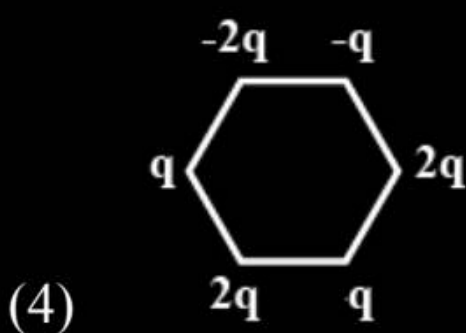
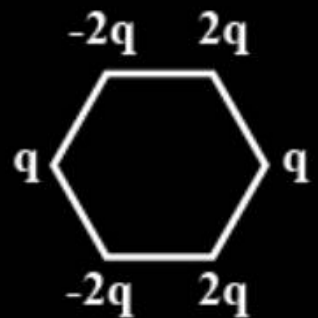
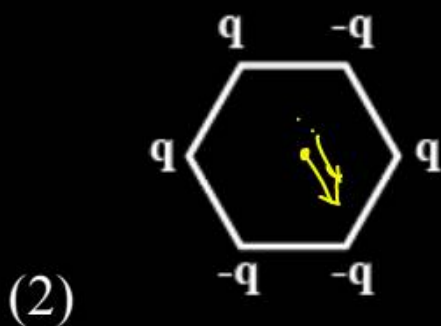
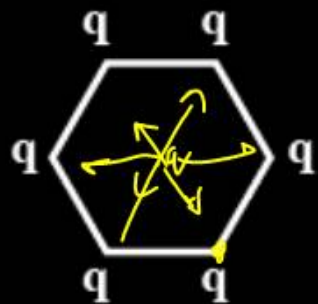

Question no. 32

A and B are two infinitely long straight parallel conductors. C is another straight conductor of length 1 m kept parallel to A and B as shown in the figure. Then, the force experienced by C is

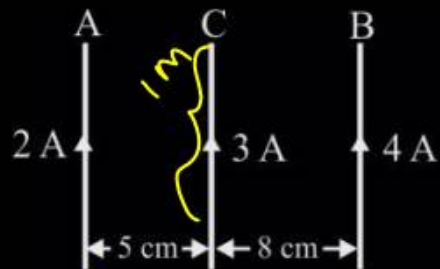

- (1) ~~towards A equal to $0.6 \times 10^{-5} \text{N}$~~
- (2) towards B equal to $5.4 \times 10^{-5} \text{N}$
- (3) ~~towards A equal to $5.4 \times 10^{-5} \text{N}$~~
- (4) towards B equal to $0.6 \times 10^{-5} \text{N}$

$$\frac{f}{l} = \frac{\mu_0}{2\pi} \frac{I_1 I_2}{r}$$

(AC)

$$f_1 = \frac{\mu_0}{2\pi} \frac{2 \times 3 \times 1}{0.05}$$

(BC)

$$f_2 = \frac{\mu_0}{2\pi} \frac{3 \times 4 \times 1}{0.08}$$

$$f_{\text{net}} = \frac{\mu_0}{2\pi} (30) = \frac{4\pi \times 10^{-7}}{2\pi} \times 30 = 60 \times 10^{-7} = 0.6 \times 10^{-5}$$

$$= \frac{120 \mu_0}{2\pi} = 150 \frac{\mu_0}{2\pi}$$

Question no. 33

Light of wavelength λ_A and λ_B falls on two identical metal plates A and B respectively. The maximum kinetic energy of photoelectrons is K_A and K_B respectively, then which one of the following relations is true? ($\lambda_A = 2\lambda_B$)

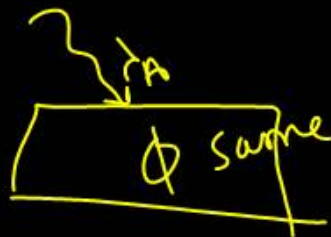

(1) $K_A < \frac{K_B}{2}$

(2) $2K_A = K_B$

(3) $K_A = 2K_B$

(4) $K_A > 2K_B$

$$K_{EA} = \frac{hc}{\lambda_A} - \phi$$

$$2K_{EA} = 2\frac{hc}{\lambda_A} - 2\phi$$

$$2K_{EA} + \phi = \frac{2hc}{\lambda_A} - \phi$$

$$K_{EB} = \frac{hc}{\lambda_B} - \phi$$

$$K_{EB} = \frac{2hc}{\lambda_A} - \phi$$

$$2K_{EA} + \phi = K_{EB}$$

$$2(K_{EA}) + \phi = K_{EB}$$

$$2K_{EA} = \frac{K_{EB} - \phi}{2}$$

$$K_{EA} = \frac{K_{EB} - \phi}{2}$$

Question no. 34

A stone of mass of 16 kg is attached to string 144 m long and is whirled in a horizontal circle on a smooth surface. The maximum tension in the string that it can withstand is 16 N. The maximum velocity of revolution that can be given to the stone without breaking it, will be

- (1) 20 ms^{-1} (2) 16 ms^{-1}
(3) 14 ms^{-1} (4) 12 ms^{-1}



$$T_{\max} = 16 \text{ N}$$
$$T = \frac{mv^2}{r}$$

$$16 = \frac{16 \cdot v^2}{144}$$

$$v^2 = 144$$
$$v = 12$$

Question no. 35

A meter stick is balanced on a knife edge at its centre. When two coins, each of mass 5 g are put one on top of the other at the 12 cm mark, the stick is found to be balanced at 45 cm. The mass of the meter stick is

- (1) 56 g (2) 66 g
 (3) 76 g (4) 86 g

2

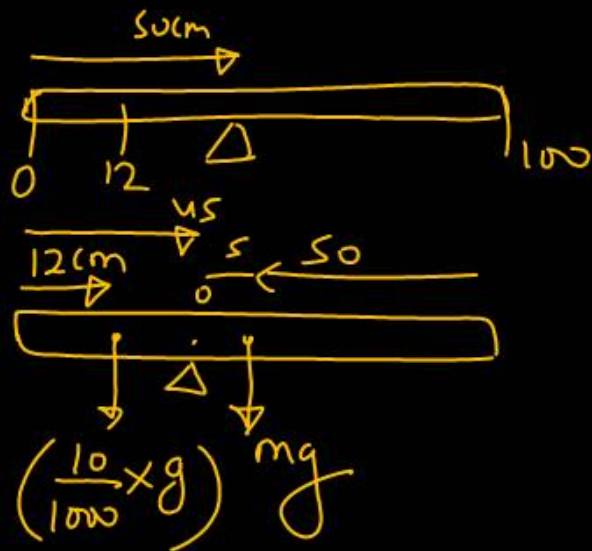

$$\sum \tau_0 = 0$$

$$\frac{10}{1000} \times 10 \times 33 = mg \times 5$$

$$\frac{33}{100 \times 5} \text{ kg} = m$$

$$\frac{66}{1000} \text{ kg} = m$$

Question no. 36

A bob of mass m is suspended by a light string of length L . It is imparted a horizontal velocity v_0 at the lowest point. A such that it completes a semicircular trajectory in the vertical plane with the string becoming slack only on reaching the topmost point, C.

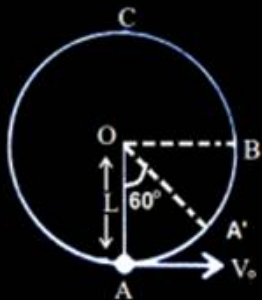

Match the Column I with Column II.

	Column-I		Column-II
(A)	Velocity v_0 is	(p)	$\sqrt{4gL}$
(B)	Velocity at point B is	(q)	\sqrt{gL}
(C)	Velocity at point C is	(r)	$\sqrt{5gL}$
(D)	Velocity at point A' is	(s)	$\sqrt{3gL}$

(1) A - p, B - q, C - s, D - r

(2) A - q, B - r, C - p, D - s

(3) A - r, B - s, C - q, D - p

(4) A - s, B - p, C - r, D - q

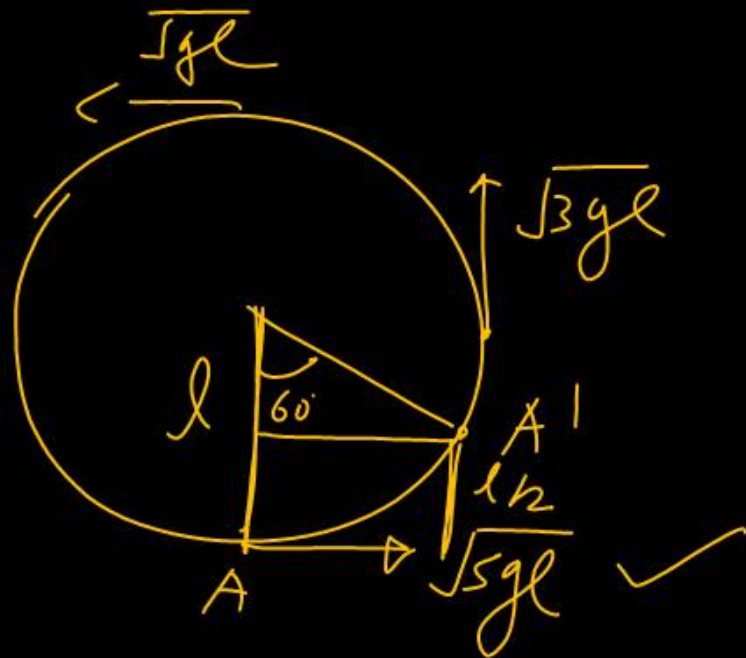

A \rightarrow A'

$$0 + \frac{1}{2} m s g l = \frac{1}{2} m v_{A'}^2 + m g l / 2$$

$$4/3 g l = m v_{A'}^2$$

3

Question no. 37

A ball falls under gravity from a height of 10 m with an initial downward velocity u . It collides with the ground, loses 50% of its energy in collision and then rises back to the same height. The initial velocity u is

- (1) 7 m s^{-1} (2) 25 m s^{-1}
 (3) 14 m s^{-1} (4) 28 m s^{-1}

3

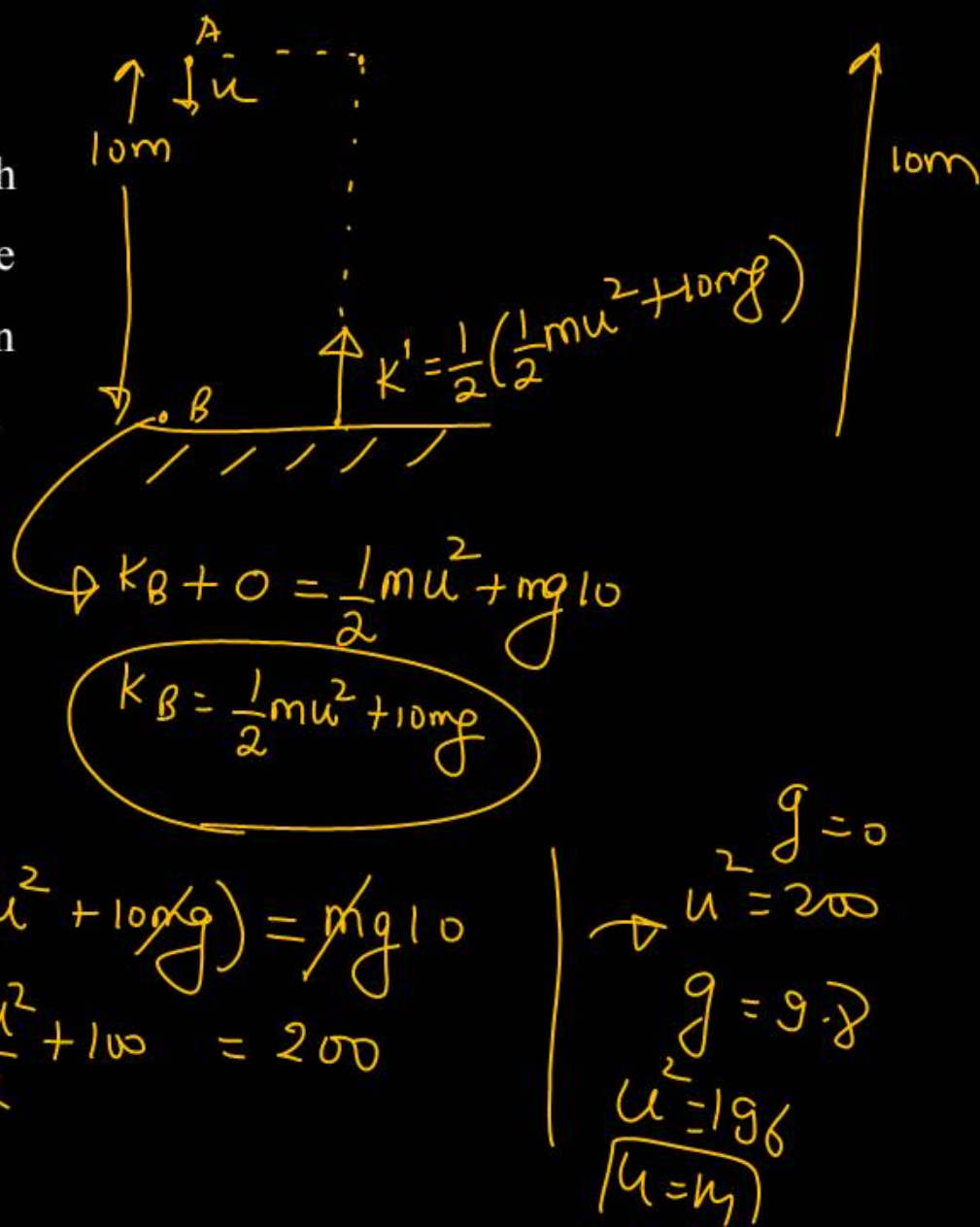

Question no. 38

A block of mass 1 kg is pushed up a surface inclined to horizontal at an angle of 30° by a force of 10 N parallel to the inclined surface as shown in the figure. The coefficient of friction between block and the incline is 0.1 . If the block is pushed up by 10 m along the incline, then the work against gravity is (Take $g = 10\text{ m s}^{-2}$)

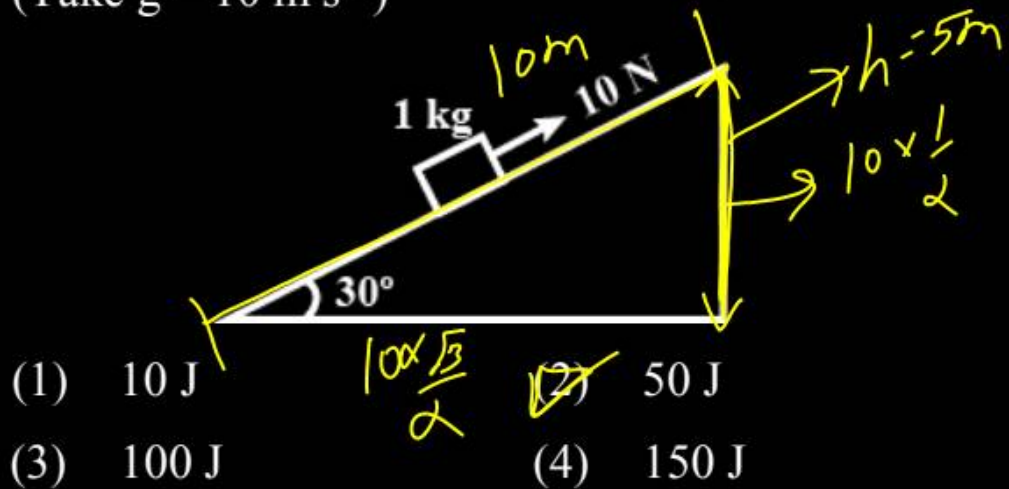

- (1) 10 J (2) 50 J
 (3) 100 J (4) 150 J

Handwritten calculations:

$$mg = 1 \times 10 \Rightarrow 10\text{ N}$$

$$W_g = 10 \times 5 \Rightarrow 50\text{ J}$$

Question no. 39

A planet revolves round the sun in an elliptical orbit.

The linear speed of the planet will be maximum at

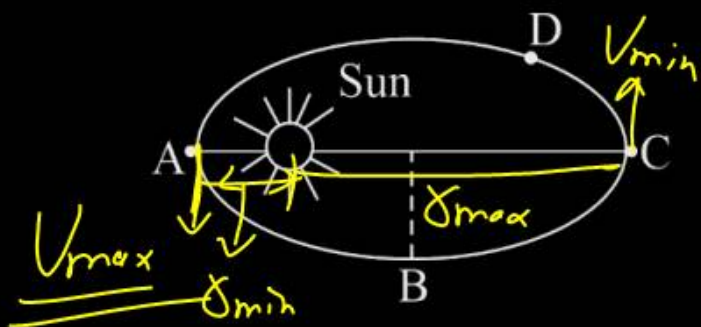

\hookrightarrow east.

$m v \delta \rightarrow \text{const.}$

$V \delta \rightarrow \text{const.}$

(1) D

(2) B

(3) A

(4) C

Question no. 40

The ratio of escape velocity at earth (v_e) to the escape velocity at a planet (v_p) whose radius and mean density are twice as that of earth is

- (1) 1 : 4 (2) 1 : $\sqrt{2}$
 (3) 1 : 2 (4) ~~1~~ 1 : $2\sqrt{2}$

$$v_e = \sqrt{\frac{2GM}{R}}$$

$$v_e = \sqrt{\frac{2 \times G \times \frac{4}{3} \times \rho \times R^3 \times \rho}{R}}$$

$$v_e = \sqrt{\frac{8GM \times R^2 \times \rho}{3}}$$

$$v_e \propto \sqrt{R^2 \rho}$$

$$\frac{v_e}{v_p} = \frac{\sqrt{R^2 \rho}}{\sqrt{4R^2 \times 2\rho}}$$

$$\frac{v_e}{v_p} = \frac{1}{\sqrt{2}}$$

Question no. 41

Dependence of intensity of gravitational field (magnitude only) of earth with distance (r) from centre of earth is correctly represented by

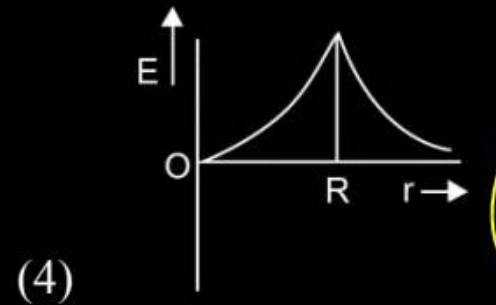
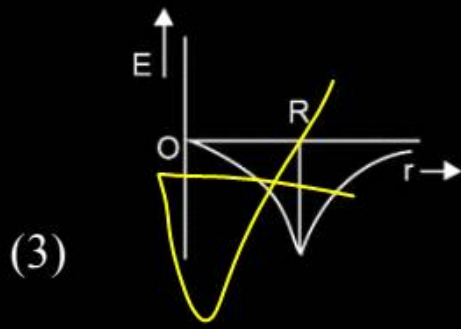
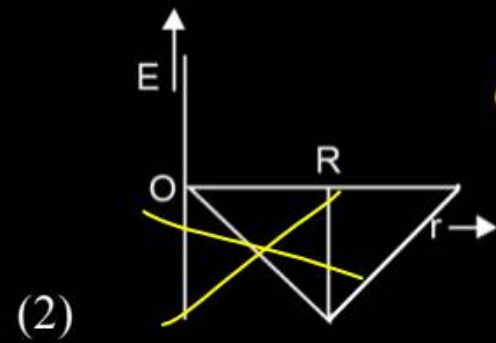
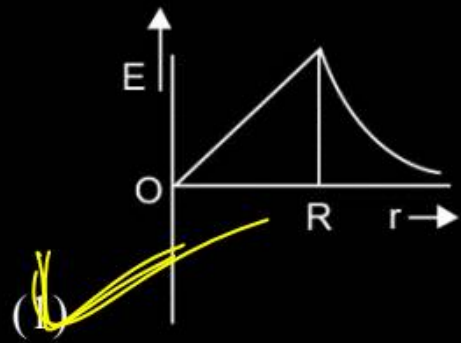

$$g_d = \frac{GM}{r^2} \propto r^{-2}$$

$g_d \propto r$ st. line

$g_d \propto \frac{1}{r^2}$ → Hypocube

Question no. 42

A capacitor is charged by a battery and the energy stored is U. The battery is now removed and the separation distance between the plates is doubled. The energy stored now is

(1) $\frac{U}{2}$

(2) U

~~(3) 2U~~

(4) 4U

$$U = \frac{q^2}{2C} = \frac{q^2}{2(\epsilon_0 A/d)} = \frac{q^2 d}{2\epsilon_0 A}$$

Question no. 43

A charged particle enters in a uniform magnetic field with a certain ^{fix} speed at right angles to it. In the magnetic field, a change could occur in its

- (1) kinetic energy *force \perp velocity . $W_D = 0$*
- (2) angular momentum ,
- (3) linear momentum
- (4) speed

Question no. 44

A silicon specimen is made into a p-type semiconductor by doping on an average one indium atom per 5×10^7 silicon atoms. If the number density of atoms in the silicon specimen is 5×10^{28} atom/m³, then the number of acceptor atoms in silicon per cubic centimeter will be

$$\begin{aligned} \text{Si number density} &= 5 \times 10^{28} \text{ atom/m}^3 \\ &= 5 \times 10^{28-6} = 5 \times 10^{22} \text{ atom/cm}^3 \end{aligned}$$

- (1) 2.5×10^{30} atom/cm³
- (2) 2.5×10^{35} atom/cm³
- (3) 1.0×10^{13} atom/cm³
- (4) 1.0×10^{15} atom/cm³

$$\begin{aligned} 1 \text{ atom indium} &\rightarrow 5 \times 10^7 \text{ Si} \\ \text{Total} &= \frac{5 \times 10^{22}}{5 \times 10^7} = 10^{15} \end{aligned}$$

Question no. 45

A pendulum bob on a 2m string is displaced 60° from the vertical and then released. What is the speed of the bob as it passes through the lowest point in its path?

- (1) $\sqrt{2} \text{ ms}^{-1}$ (2) $\sqrt{9.8} \text{ ms}^{-1}$
 (3) 4.43 ms^{-1} (4) $\frac{1}{\sqrt{2}} \text{ ms}^{-1}$

$$mgh = \frac{1}{2} m v^2$$

$$v^2 = 2gh$$

$$= \sqrt{2 \cdot 10 \cdot 2} = \sqrt{20} \approx 4.4$$

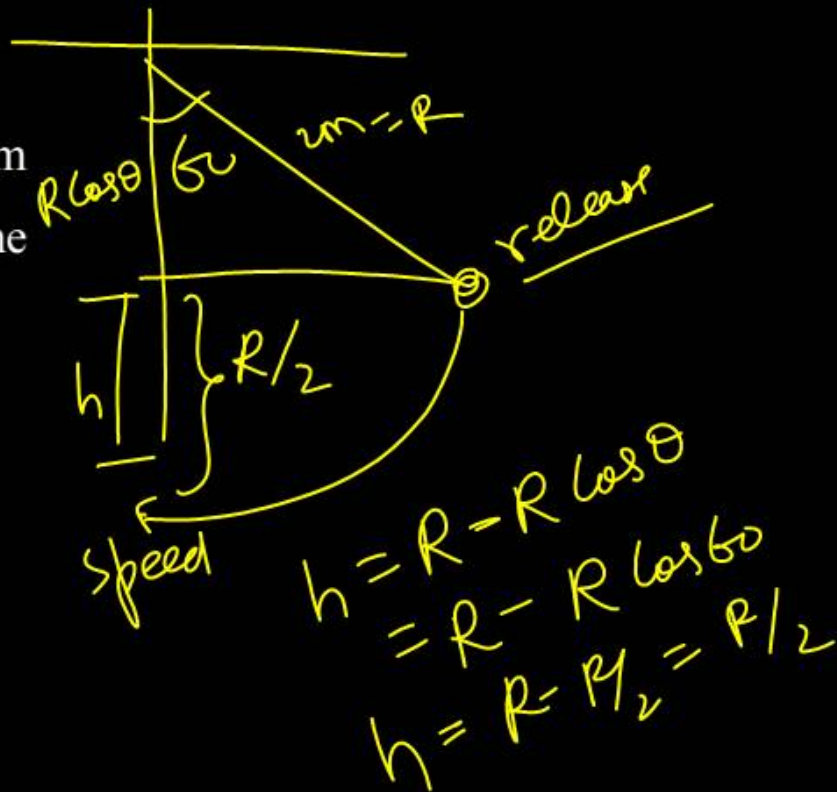

Question no. 46

Match the List-I with List-II and mark the appropriate choice.

	List-I		List-II
A.	$\text{H}_2(\text{g}) + \text{Br}_2(\text{g}) \rightarrow 2\text{HBr}(\text{g})$	i.	$\Delta H = \Delta U - 2RT$
B.	$\text{PCl}_5(\text{g}) \rightarrow \text{PCl}_3(\text{g}) + \text{Cl}_2(\text{g})$	ii.	$\Delta H = \Delta U + 3RT$
C.	$\text{N}_2(\text{g}) + 3\text{H}_2(\text{g}) \rightarrow 2\text{NH}_3(\text{g})$	iii.	$\Delta H = \Delta U$
D.	$2\text{N}_2\text{O}_5(\text{g}) \rightarrow 4\text{NO}_2(\text{g}) + \text{O}_2(\text{g})$	iv.	$\Delta H = \Delta U + RT$

- (1) A - iii, B - i, C - ii, D - iv
 (2) A - iii, B - iv, C - i, D - ii
 (3) A - ii, B - i, C - iv, D - iii
 (4) A - iv, B - ii, C - i, D - iii

$$\Delta H = \Delta U + \Delta n_g RT$$

$$\Delta n_g = 0$$

$$\Delta n_g = 2 - 1 = +1$$

$$\Delta n_g = 2 - 4 = -2$$

$$\Delta n_g = 5 - 2 = +3$$

Question no. 47

On the basis of thermochemical equations (i), (ii) and (iii), find out which of the algebraic relationships given in options is correct.



(1) $z = x + y$

(2) $x = y - z$

(3) $x = y + z$

(4) $y = 2z - x$

$$z = x - y$$

$$z + y = x$$

Question no. 48

2 moles of an ideal gas are expanded isothermally and reversibly from 1 L to 10 L at 300 K. What is the work done?

- (1) 4.98 kJ (2) 11.47 kJ
(3) -11.47 kJ (4) 0 kJ

$$\begin{aligned}W &= -2.303 n R T \log_{10} \frac{V_2}{V_1} \\&= -2.3 \times \frac{2 \times 25}{10} \times 300 \log_{10} \frac{10}{1} \\&= -2.3 \times 5\end{aligned}$$

Question no. 49

The values of ΔH and ΔS for the reaction, $\text{C}_{(\text{graphite})} + \text{CO}_2(\text{g}) \rightarrow 2\text{CO}(\text{g})$ are 170 kJ & 170 J K^{-1} , respectively. This reaction will be spontaneous at

- (1) 510 K (2) 710 K
 (3) 910 K (4) 1110 K



$$\Delta G^{\circ} = \Delta H^{\circ} - T\Delta S^{\circ}$$

$$T = \frac{\Delta H^{\circ}}{\Delta S^{\circ}}$$

$$= \frac{170 \times 1000}{170}$$

$$\Delta G^{\circ} = -ve$$

Spontaneous

Question no. 50

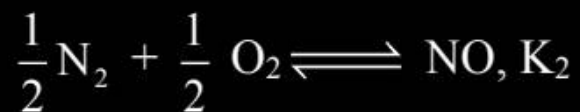

What will be correct relation between equilibrium constants of above reactions :

(1) $K_1 = K_2$

(2) $K_1 = 2K_2$

(3) ~~$K_2 = \sqrt{K_1}$~~

(4) $K_1 = \frac{1}{2} K_2$

$$K_{eq} = (K_1)^{1/n}$$

$$K_{eq} = (K_1)^{1/2}$$

$$K_{eq} = \sqrt{K_1}$$

Question no. 51

Which of the following solutions will have pH close to 1.0?

- (1) 100 ml of (M/10) HCl + 100 ml of (M/10) NaOH
- (2) 55 ml of (M/10) HCl + 45 ml of (M/10) NaOH
- (3) 10 ml of (M/10) HCl + 90 ml of (M/10) NaOH
- (4) 75 ml of (M/10) HCl + 25 ml of (M/10) NaOH

pH scale :-

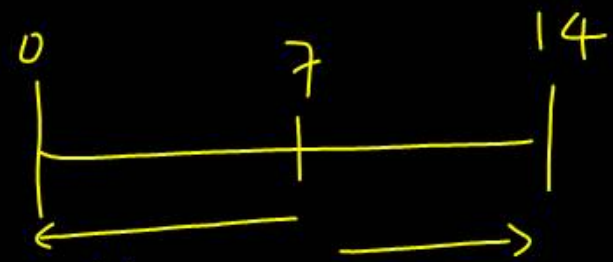

Acidic

Basic

↑
pH close to 1

↓
Basic

Question no. 52

Phosphorus pentachloride dissociates as follows, in a closed reaction vessel



If total pressure at equilibrium of the reaction mixture is P and degree of dissociation of PCl_5 is x, the partial pressure of PCl_3 will be

(1) $\left(\frac{x}{x+1}\right)P$

(2) $\left(\frac{2x}{1-x}\right)P$

(3) $\left(\frac{x}{x-1}\right)P$

(4) $\left(\frac{x}{1-x}\right)P$

Handwritten solution:

$$\text{PCl}_5 \rightleftharpoons \text{PCl}_3 + \text{Cl}_2$$

a	0	0	
a-x	x	x	$n_{\uparrow} = (a+x)$

M.F

$$\left(\frac{a-x}{a+x}\right) \quad \left(\frac{x}{a+x}\right) \quad \left(\frac{x}{a+x}\right)$$

$PP = M \times P_{\uparrow}$

$$\left(\frac{a-x}{a+x} P_{\uparrow}\right) \quad \left(\frac{x}{a+x} P_{\uparrow}\right) \quad \left(\frac{x}{a+x} P_{\uparrow}\right)$$

$\left(\frac{x}{1+x} P\right) = PP \text{ PCl}_3 = \left(\frac{x}{a+x} P_{\uparrow}\right)$

\downarrow
1

Question no. 53

50 litres of 0.1 M HCl are mixed with 50 litres of 0.2 M NaOH. The pH of the resulting solution is

- (1) 12.70 (2) 12.34
 (3) 8.7 (4) 4.2

$$\text{Acid } N_1V_1 = 50 \times 0.1 = 5$$

$$\text{Base } N_2V_2 = 50 \times 0.2 = 10$$

Base > Acid solⁿ is basic

$$[\text{OH}^-] = \frac{[\text{Base}] - [\text{Acid}]}{V_1 + V_2}$$

$$[\text{OH}^-] = \frac{10 - 5}{100} = \frac{5}{100} = 5 \times 10^{-2}$$

$$p\text{OH} = 2 - \log 5$$

$$= 2 - 0.7 = 1.3$$

$$p\text{H} = 14 - 1.3 = 12.7$$

Which of the following order of energies of molecular orbitals of N_2 is correct?

- ✓ (1) $(\pi 2p_y) < (\sigma 2p_z) < (\pi^* 2p_x) \approx (\pi^* 2p_y)$
- (2) $(\pi 2p_y) > (\sigma 2p_z) > (\pi^* 2p_x) \approx (\pi^* 2p_y)$
- (3) $(\pi 2p_y) < (\sigma 2p_z) > (\pi^* 2p_x) \approx (\pi^* 2p_y)$
- (4) $(\pi 2p_y) > (\sigma 2p_z) < (\pi^* 2p_x) \approx (\pi^* 2p_y)$

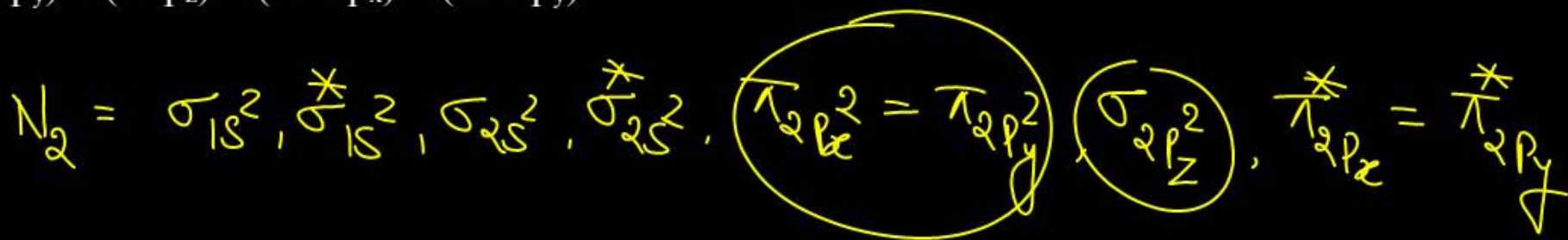

Question no. 55

Match the column and choose the correct options :

Column-I		Column-II
a.	Isothermal change	
b.	Adiabatic change	
c.	Isobaric change	
d.	Isochoric change	

(1) A - 1; B - 2; C - 3; D - 4

(2) A - 4; B - 3; C - 2; D - 1

(3) A - 3; B - 2; C - 4; D - 1

(4) A - 1; B - 4; C - 2; D - 3

Question no. 56

5 moles of SO_2 and 5 moles of O_2 are allowed to react. At equilibrium, it was found that 60% of SO_2 is used up. If the partial pressure of the equilibrium mixture is one atmosphere, the partial pressure of O_2 is

(1) 0.52 atm

(2) 0.21 atm

(3) 0.41 atm

(4) 0.82 atm

$n_{\text{T}} = 8.5$

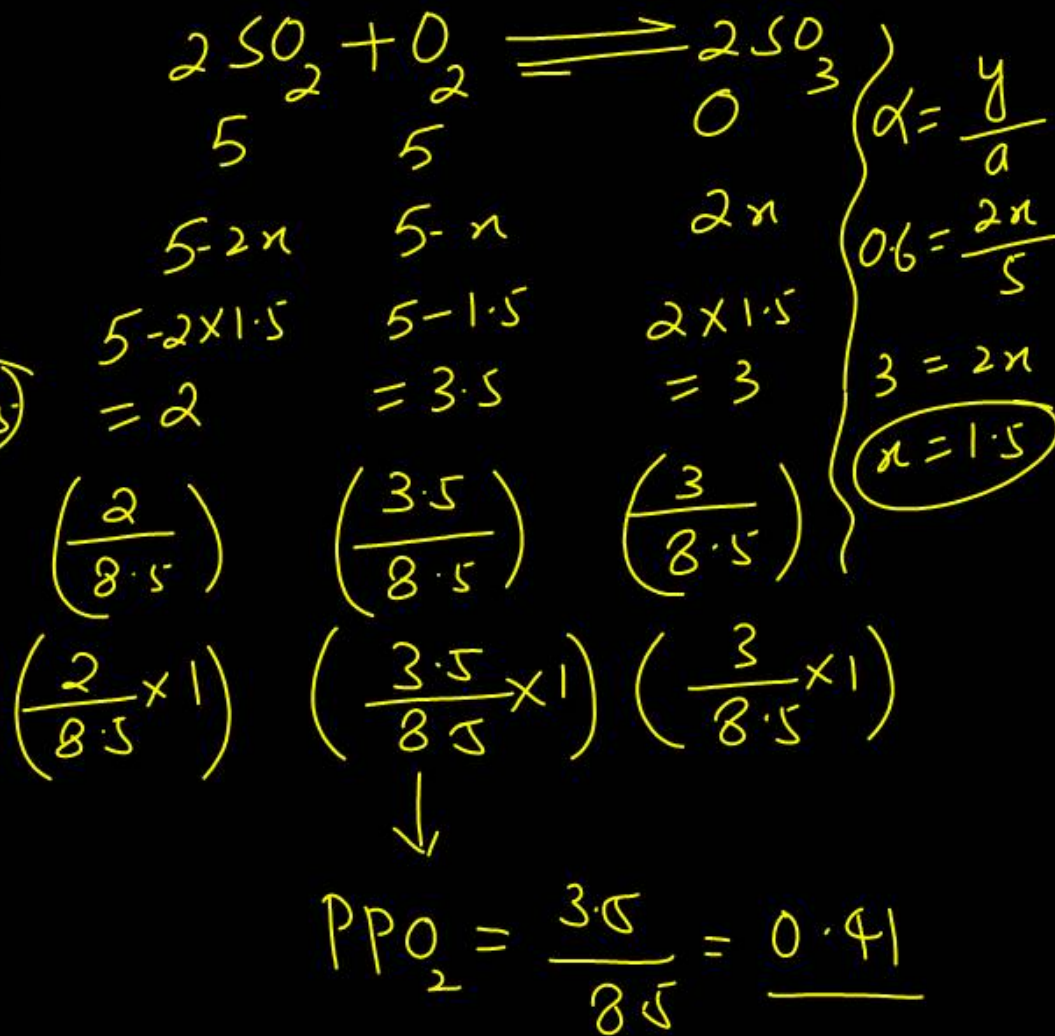

Which of the following is most likely structure of
 $\text{CrCl}_3 \cdot 6\text{H}_2\text{O}$ if $1/3$ of total chlorine of the compound is
precipitated by adding AgNO_3 to its aqueous solution?

- (1) $\text{CrCl}_3 \cdot 6\text{H}_2\text{O}$
- (2) $[\text{Cr}(\text{H}_2\text{O})_3\text{Cl}_3] (\text{H}_2\text{O})_3$
- (3) $[\text{CrCl}_2(\text{H}_2\text{O})_4] \underline{\text{Cl} \cdot 2\text{H}_2\text{O}}$
- (4) $[\text{CrCl}(\text{H}_2\text{O})_5] \text{Cl}_2 \cdot \text{H}_2\text{O}$

Cl

Question no. 58

If at 298 K the bond energies of C - H, C - C, C = C and H - H bonds are respectively 414, 347, 615 and 435 kJ mol⁻¹, the value of enthalpy change for the reaction $\text{H}_2\text{C}=\text{CH}_2(\text{g}) + \text{H}_2(\text{g}) \rightarrow \text{H}_3\text{C}-\text{CH}_3(\text{g})$ at 298 K will be :

- (1) +250 kJ (2) -250 kJ
 (3) +125 kJ (4) -125 kJ

$$\Delta H_{\text{Reaction}} = \text{B.E.}_R - \text{B.E.}_P$$

$$\Delta H = \left[(\text{C-H}) \times 4 + (\text{C}=\text{C}) + (\text{H-H}) \right] - \left[(\text{C-H}) \times 6 + (\text{C-C}) \right]$$

$$\Delta H = \left(414 \times 4 + 615 + 435 \right) - \left(414 \times 6 + 347 \right)$$

$$= -125$$

Based on the first law of thermodynamics, which one of the following is correct?

- (1) For an isothermal process, $q = +W$
- (2) For an isochoric process, $\Delta U = -q$
- (3) For an adiabatic process, $\Delta U = -W$
- (4) For a cyclic process, $q = -W$

$$\Delta U = q + W$$

$$\Delta T = 0 \quad \Delta U = 0 \quad q = -W$$

$$W = 0 \quad \Delta U = q$$

$$q = 0 \quad \Delta U = W$$

$$\Delta U = 0$$

$$q = -W$$

The heat of neutralization of a strong acid and a strong alkali is 57.0 kJ mol^{-1} . The heat released when 0.5 mole of HNO_3 solution is mixed with 0.2 mole of KOH is

(1) 57.0 kJ

~~(2) 11.4 kJ~~

(3) 28.5 kJ

(4) 34.9 kJ

| 57
 0.2×57

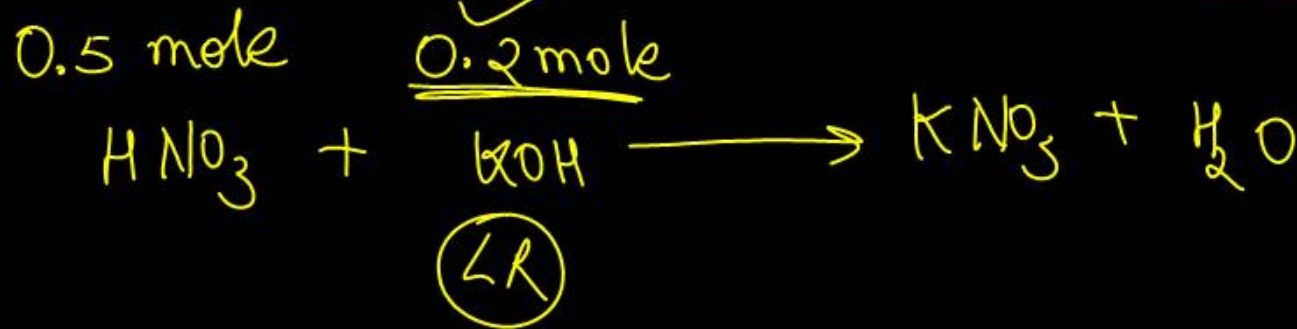

Question no. 61

Which one of the following has ΔS° greater than zero?

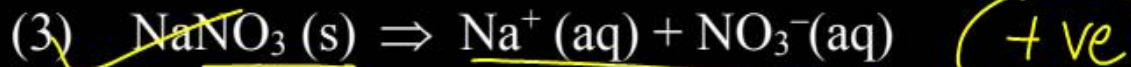
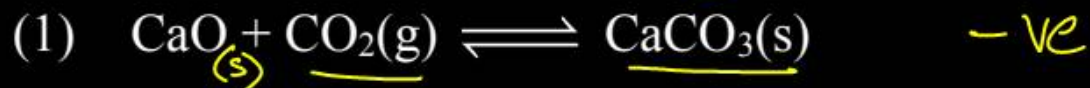

$\Delta S^\circ > 0$ +ve
Spontaneous

Question no. 62

The solubility in water of a sparingly soluble salt AB_2 is $1.0 \times 10^{-5} \text{ mol L}^{-1}$. Its solubility product number will be :

(1) 4×10^{-15}

(2) 4×10^{-10}

(3) 1×10^{-15}

(4) 1×10^{-10}



$$K_{sp} = [s][2s]^2 = 4s^3$$

$$K_{sp} = 4 \times (10^{-5})^3$$
$$= 4 \times 10^{-15}$$

Which one of the following pair show buffer's solution?

- (1) $\text{NaCl} + \text{NaOH}$ X
- (2) $\text{CH}_3\text{COONa} + \text{CH}_3\text{COOH}$ ✓
WASB WA
- (3) $\text{CH}_3\text{COOH} + \text{CH}_3\text{COONH}_4$ X
- (4) $\text{H}_2\text{SO}_4 + \text{CuSO}_4$ X

WA + WB

WA / WB + salt of this WA / WB with SB / SA

The reaction quotient (Q) for the reaction $\text{N}_2(\text{g})$
 $+ 3\text{H}_2(\text{g}) \rightleftharpoons 2\text{NH}_3(\text{g})$ is given by $Q = \frac{[\text{NH}_3]^2}{[\text{N}_2][\text{H}_2]^3}$.
forward

The reaction will proceed towards right side if

- (1) ~~$Q < K_c$~~ (2) $Q = 0$
 (3) $Q = K_c$ (4) $Q > K_c$

$K_{eq} = Q$	Eqm
$K_{eq} > Q$	forward
$K_{eq} < Q$	Backward

Match the columns.

	Column-I		Column-II
A	$\text{H}_2(\text{g}) + \text{I}_2(\text{g}) \rightleftharpoons 2\text{HI}(\text{g})$	p	$K_p = K_c (RT)$
B	$\text{N}_2(\text{g}) + 3\text{H}_2(\text{g}) \rightleftharpoons 2\text{NH}_3(\text{g})$	q	$K_p = K_c (RT)^2$
C	$\text{PCl}_5(\text{g}) \rightleftharpoons \text{PCl}_3(\text{g}) + \text{Cl}_2(\text{g})$	r	$K_p = K_c (RT)^{-2}$
D	$\text{NH}_4\text{Cl}(\text{s}) \rightleftharpoons \text{NH}_3(\text{g}) + \text{HCl}(\text{g})$	s	$K_p = K_c$

- ✓ (1) A - s; B - r; C - p; D - q
- (2) A - q; B - s; C - r; D - p
- (3) A - p; B - r; C - q; D - s
- (4) A - r; B - p; C - r; D - p

$$K_p = K_c (RT)^{\Delta n_g}$$

$$\Delta n_g = 0 \quad K_p = K_c$$

$$\Delta n_g = -ve = -2$$

$$\Delta n_g = +ve = +1$$

The electronic configuration of the outer most shell of the most electronegative element is :

- (1) $2s^2 2p^5$ F
- (2) $3s^2 3p^5$ Cl
- (3) $4s^2 4p^5$ Br
- (4) $5s^2 5p^5$ I

Question no. 67



The heat of formation of $\text{NCl}_3(\text{g})$ in the terms of ΔH_1 ,

ΔH_2 and ΔH_3 is

(1) $\Delta H_f = -\Delta H_1 + \frac{\Delta H_2}{2} - \frac{3}{2}\Delta H_3$

(2) $\Delta H_f = \Delta H_1 + \frac{\Delta H_2}{2} - \frac{3}{2}\Delta H_3$

(3) $\Delta H_f = \Delta H_1 - \frac{\Delta H_2}{2} - \frac{3}{2}\Delta H_3$

(4) None of these

$$\Delta H_1 = \left(\frac{3\Delta H_3}{2}\right) + \left(\Delta H_f\right) - \frac{\Delta H_2}{2}$$

$$\Delta H_f = \Delta H_1 + \frac{\Delta H_2}{2} - \frac{3\Delta H_3}{2}$$

Question no. 68

In which of the following equilibrium system is the rate of backward reaction favoured by increase of pressure?

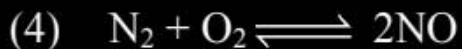
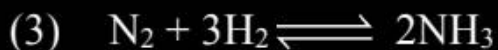
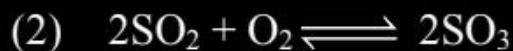

$P \uparrow$ Back Pressure \uparrow

Reaction shift in that dirⁿ where no. of mole \downarrow

If the bond dissociation energies of \underline{XY} , $\underline{X_2}$ and $\underline{Y_2}$ are in the ratio of $1 : 1 : 0.5$ and ΔH_f for the formation of \underline{XY} is -200 kJ/mole. The bond dissociation energy of X_2 will be :

- (1) 100 kJ/mole (2) 400 kJ/mole
 (3) 600 kJ/mole (4) 800 kJ/mole

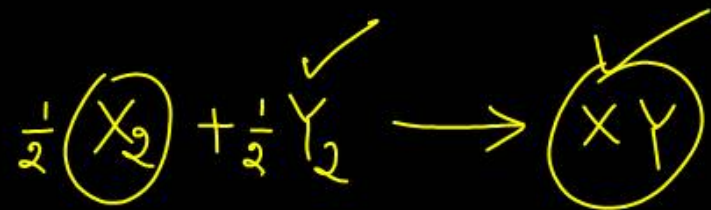

$$\Delta H_f = B.F.R - B.F.P$$

$$-200 = \left(\frac{x}{2} + \frac{x}{4} \right) - x$$

$$-200 = \frac{3x}{4} - x$$

$$-200 = \frac{1}{4}x$$

Which of the following is the correct option for free expansion of an ideal gas under adiabatic condition?

(1) $q = 0, \Delta T < 0, W \neq 0$

(2) $q = 0, \Delta T \neq 0, W = 0$

(3) $q \neq 0, \Delta T = 0, W = 0$

(4) $q = 0, \Delta T = 0, W = 0$

$$W = 0, q = 0$$

$$\Delta U = q + W$$

$$\Delta U = 0$$
$$\Delta T = 0$$

The enthalpy of combustion at 25°C of H_2 , cyclohexene (C_6H_{10}) and cyclohexane (C_6H_{12}) are -241 , -3800 and -3920 kJ/mol respectively. The heat of hydrogenation of cyclohexene is

- (1) -121 kJ/mole (2) $+121$ kJ/mole
 (3) -242 kJ/mole (4) $+242$ kJ/mole



$$\Delta H_{\text{Reaction}} = (-3800 - 241) - (-3920)$$

$$= -4041 + 3920$$

Question no. 72

If w_1 , w_2 , w_3 and w_4 for an ideal gas are work done in reversible isothermal, reversible adiabatic, isobaric and isochoric expansion process, the correct order will be (magnitude only)

- (1) $w_1 > w_2 > w_3 > w_4$ (2) $w_3 > w_2 > w_1 > w_4$
(3) $w_3 > w_2 > w_4 > w_1$ (4) $w_3 > w_1 > w_2 > w_4$

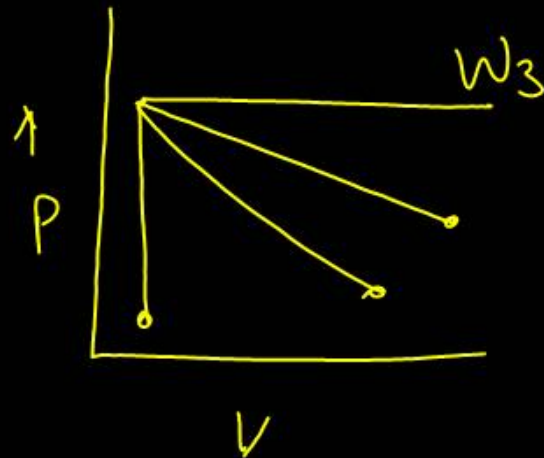

$w_3 > w_1 > w_2 > w_4$

Question no. 73

Hydrogen ion concentration in mol/L in solution of pH

5.4 will be :

(1) 3.88×10^6

~~(2) 3.98×10^{-6}~~

(3) 3.98×10^8

(4) 3.68×10^{-6}

$$\text{pH} = -\log [\text{H}^+]$$

$$\text{pH} = 5.4$$

$$[\text{H}^+] = 4 \times 10^{-6}$$

$$5 + 1 = 6$$
$$1 - 0.4 = 0.6$$

Question no. 74

For the following reactions a, b and c equilibrium constants are given :



Which of the following relations is correct?

(1) $K_1\sqrt{K_2} = K_3$ (2) $K_2K_3 = K_1$

(3) $K_3 = K_1K_2$ (4) $K_3 = K_2^3K_1^2$

$$K_3 = K_1 \times K_2$$

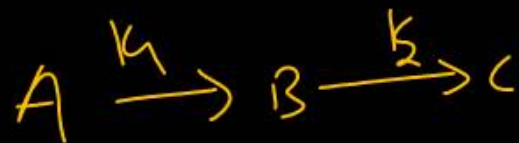

$$K_{eq} = K_1 \times K_2$$

Question no. 75

In the reaction $\text{N}_2(\text{g}) + 3\text{H}_2(\text{g}) \rightleftharpoons 2\text{NH}_3(\text{g})$, $\Delta H = -96.6\text{kJ}$ the yield of ammonia does not increase when

- (1) Pressure is increased
- (2) Pressure is decreased
- (3) Temperature is lowered
- (4) Volume of the reaction vessel is decreased

Pressure \uparrow Rxn forward $\text{NH}_3 \uparrow$
Pressure \downarrow Rxn backward $\text{NH}_3 \downarrow$

2

Question no. 76

Number of π -bonds and σ bonds in the following structure is –

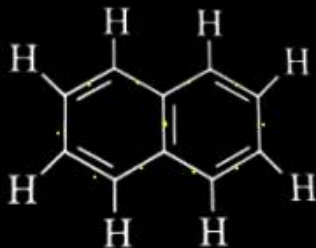

5 π

$$11\sigma + 8\sigma = 19\sigma$$

(1) 6, 19

(2) 4, 20

(3) 5, 19

(4) 5, 20

Question no. 78

The pH of the solution containing 50 mL each of 0.10

M sodium ^{Salt} acetate and 0.01 M ^{Acid} acetic acid is

[Given pK_a of $CH_3COOH = 4.57$]

(1) 4.57

(2) 2.57

(3) 5.57

(4) 3.57

Acidic
Buffer

$$pH = pK_a + \log \frac{[Salt]}{[Acid]}$$

$$= 4.57 + \log \frac{0.1}{0.01}$$

$$= 4.57 + \log 10^1$$

$$= 4.57 + 1$$

$$= \underline{5.57}$$

Strongest metallic bonding is seen with which of the following electronic configuration ?



For a spontaneous process, the correct statement is :

- (1) Entropy of the system always increases ✗
- (2) Free energy of the system always increases +ve ✗
- (3) Total entropy change is always negative -ve ✗
- (4) Total entropy change is always positive

$$\left\{ \begin{array}{l} \Delta S_{\text{total}} = +ve \\ \Delta G^{\circ} = -ve \end{array} \right\}$$

The correct thermodynamic conditions for the spontaneous reaction at all temperatures is

(1) $\Delta H > 0$ and $\Delta S < 0$ (2) $\Delta H < 0$ and $\Delta S > 0$

(3) $\Delta H < 0$ and $\Delta S < 0$ (4) $\Delta H = 0$ and $\Delta S < 0$

$$\Delta G^\circ = \Delta H^\circ - T\Delta S^\circ$$

$$= +\Delta H^\circ + T\Delta S^\circ$$

$$= +ve$$

$$\Delta G^\circ = (-\Delta H^\circ) - T\Delta S^\circ$$

$$= -ve$$

Question no. 82

The enthalpy changes for the following processes are listed below :

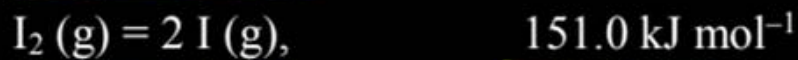
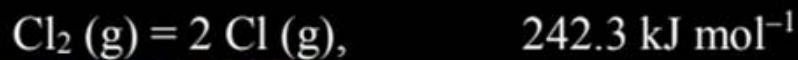

Given that the standard states for iodine and chlorine are $\text{I}_2(\text{s})$ and $\text{Cl}_2(\text{g})$, the standard enthalpy of formation for $\text{ICl}(\text{g})$ is?

(1) $+16.8 \text{ kJ mol}^{-1}$ (2) $+244.8 \text{ kJ mol}^{-1}$

(3) $-14.6 \text{ kJ mol}^{-1}$ (4) $-16.8 \text{ kJ mol}^{-1}$

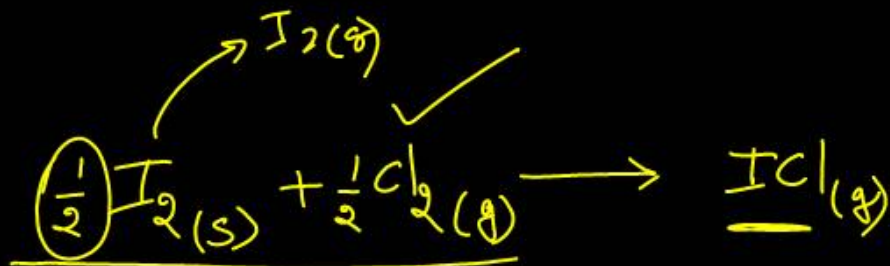

$$\Delta H_f = \left[\left(\frac{62.76 + 151}{2} \right) + \left(\frac{242.3}{2} \right) \right] - [211.3]$$

$$= +16$$

The relation between K_p and K_c for the following reaction will be



(1) $K_p = K_c (RT)^{-1}$

(2) $K_p = K_c$

(3) $K_p = K_c / (RT)^2$

(4) $K_p = K_c / RT$

$\Delta n_g = n_p - n_R = 2 - 3 = -1$

$K_p = K_c (RT)^{\Delta n_g}$

$K_p = K_c (RT)^{-1}$

$K_p = K_c / RT$

Question no. 84

The solubility of AgCl in 0.2 M NaCl will be –

(Given : $K_{sp} \text{AgCl} = 1.8 \times 10^{-10}$)

(1) $1.8 \times 10^{-11} \text{ M}$

~~(2) $9 \times 10^{-10} \text{ M}$~~

(3) $6.5 \times 10^{-12} \text{ M}$

(4) $5.6 \times 10^{-11} \text{ M}$

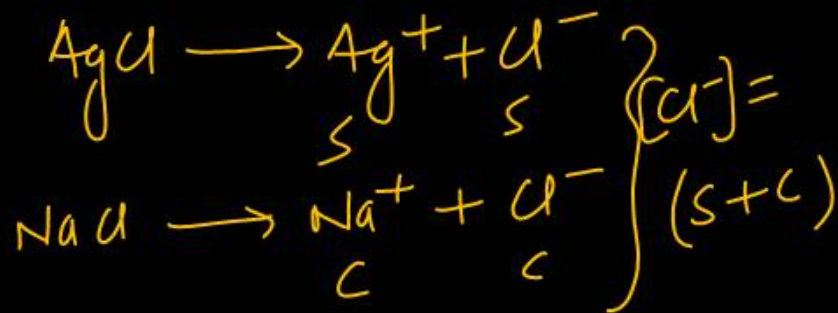

$$\begin{aligned} (K_{sp})_{\text{AgCl}} &\longrightarrow [\text{Ag}^+][\text{Cl}^-] \\ &= [s][s+c] \\ &= \cancel{[s^2]} + sc \end{aligned}$$

$$1.8 \times 10^{-10} = s \times 0.2$$

$$\begin{aligned} s' &= \frac{1.8 \times 10^{-10}}{0.2} \\ &= 9 \times 10^{-11} \end{aligned}$$

In a study of the reaction : $A + 2B \rightleftharpoons 2C + D$; A and B were mixed in a reaction vessel kept at 25°C . The initial concentration of B was 1.5 times the initial concentration of A. After the equilibrium had been established, the equilibrium concentration of A and D are equal. Calculate the equilibrium constant at 25°C .

(1) ~~4~~

(2) 6

(3) 8

(4) 12

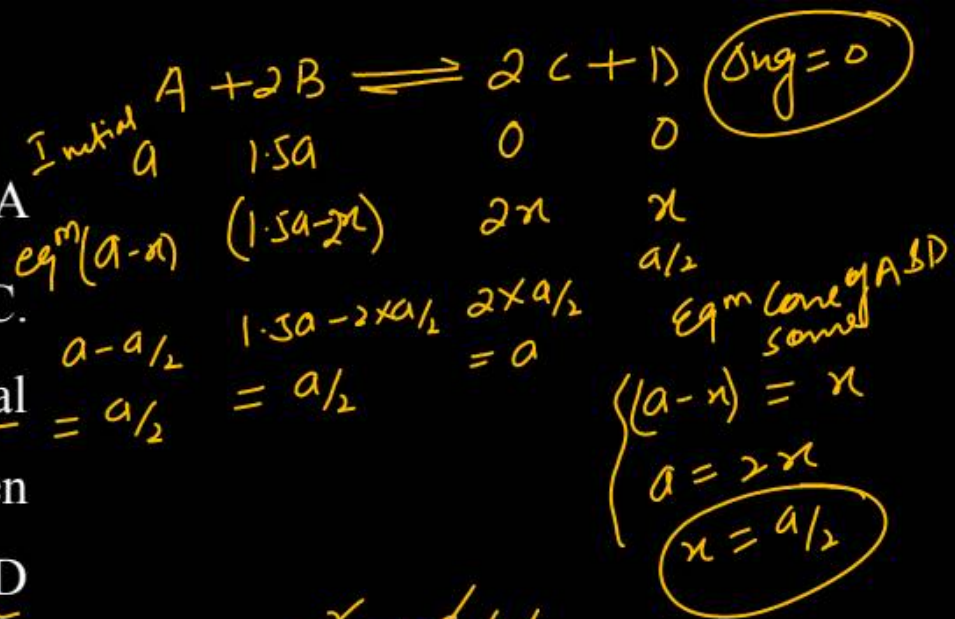

$$K_e = \frac{a^2 \times a/2}{(a/2) \times (a/2)^2}$$

$$= \frac{1}{1/4} = 4$$

$$K_e = 4$$

Question no. 86

The conjugate acid of HPO_4^{2-} is

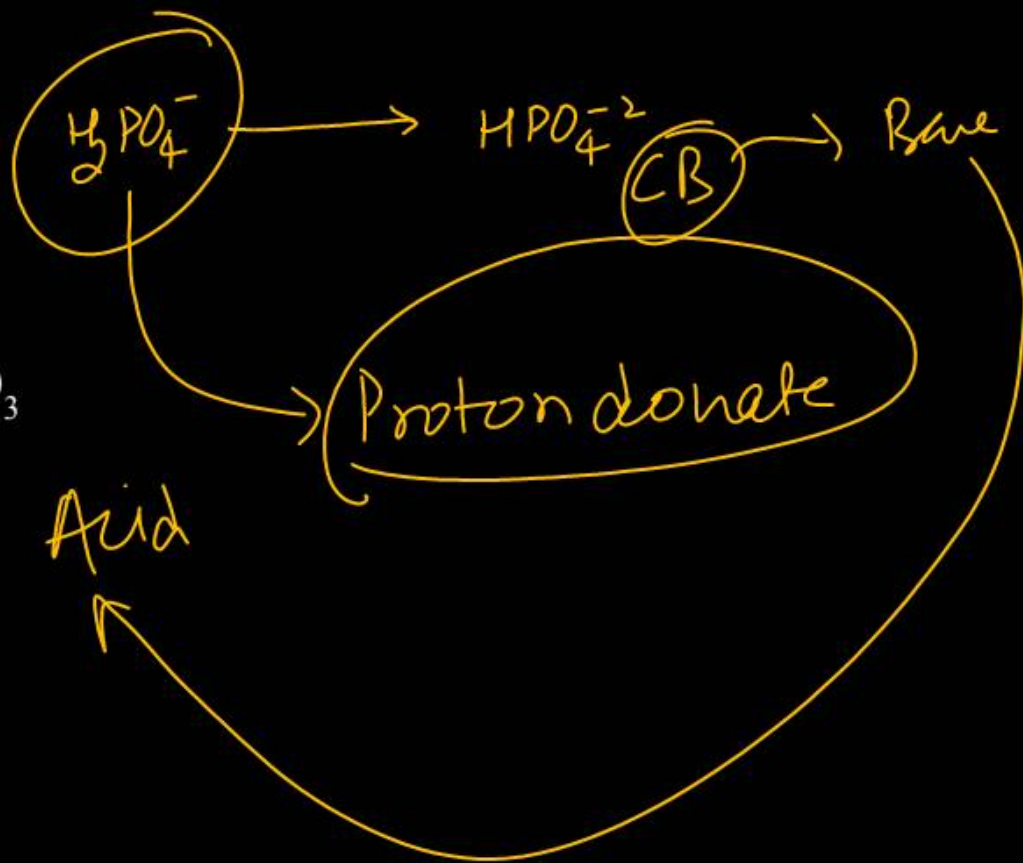

Amongst the following elements whose electronic configuration are given below, the one having the highest ionisation enthalpy is

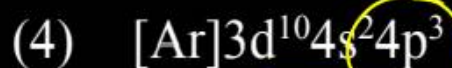

Question no. 88

Which has maximum number of molecules?



$$\frac{2}{4} = \frac{1}{2} = 0.5$$



$$\frac{1.7}{17} = \frac{1}{10} = 0.1$$

$$\frac{14}{32} \\ \frac{32}{46}$$

$$\frac{4.6}{46} = 0.1$$

$$\frac{3.2}{64} = 0.05$$

Question no. 89

The equilibrium concentrations of the species in the reaction $A + B \rightleftharpoons C + D$ are 2, 3, 10 and 6 mol L⁻¹, respectively at 300 K. ΔG° for the reaction is = 2 cal/mol K)

- (1) 1372.60 cal (2) -137.26 cal
 (3) -1381.80 cal (4) -13.73 cal

$$\Delta G = -2.303 R T \log_{10} K_{eq}$$

$$= -2.303 \times 2 \times 300 \log_{10} \frac{10 \times 6}{2 \times 3}$$

$$= -2.303 \times 2 \times 300 \log_{10} 10$$

$$= -2.303 \times 2 \times 300$$

$$\Delta G = -1381.80 \text{ cal}$$

Question no. 90

For an ideal solution, the correct option is:

- (1) $\Delta_{\text{mix}} G = 0$ at constant T and P
- (2) $\Delta_{\text{mix}} S = 0$ at constant T and P
- (3) $\Delta_{\text{mix}} V \neq 0$ at constant T and P
- ~~(4)~~ $\Delta_{\text{mix}} H = 0$ at constant T and P

Non ideal

$\Delta G_{\text{mix}} = -ve$
 $\Delta S_{\text{mix}} = +ve$ } for all

$\Delta H_{\text{mix}} = 0$

ideal soln

Question no. 91

All of the given criteria are used by R.H. Whittaker to classify organisms except

- (1) ~~Cell structure~~ (2) Body organization
(3) Habit and habitat (4) Mode of nutrition

3

Five Kingdom
Monera —
Protista —
Fungus — ph
plantae
Animalia

Question no. 92

Match column I with column II and choose the correct combination from the options given below.

	Column-I		Column-II
a.	Phycomycetes	i.	Sac fungi
b.	Ascomycetes	ii.	Imperfect fungi
c.	Basidiomycetes	iii.	Algal fungi
d.	Deuteromycetes	iv.	Club fungi/bracket fungi

- (1) a-(ii), b-(i), c-(iv), d-(iii)
- (2) a-(iii), b-(i), c-(iv), d-(ii)
- (3) a-(i), b-(ii), c-(iii), d-(iv)
- (4) a-(ii), b-(i), c-(iii), d-(iv)

(2)

Question no. 93

The correct scientific name of Mango in printed form is

(1) Mangifera Indica

~~(2) Mangifera indica~~

(3) mangifera Indica

(4) mangifera indica

Question no. 94

Choose the correct statements (i–iv) regarding mycoplasma :

- (i) Mycoplasma lack cell wall.
- (ii) Mycoplasma is the smallest cell.
- (iii) Mycoplasma cannot survive without O_2 .
- (iv) Many Mycoplasma are pathogenic in animals and plants.

- (1) Only (iii)
- (2) (i) and (iii)
- (3) (i), (ii) and (iv)
- (4) All of the above

3

Question no. 95

Which of the following is correct about viroids?

~~(1) They have free RNA without protein coat~~

(2) They have ~~DNA~~ with protein coat

(3) They have free ~~DNA~~ without protein coat

(4) They have RNA with protein coat



Question no. 96

Choose the correct option with respect to the diagram given below and its corresponding example.



Pseudo
coelomate Coelom
GΣ δΣI

- (1) Acoelomate – Platyhelminthes ✗
- (2) Pseudocoelomate – Aschelminthes
- (3) Coelomate – Ctenophores ✗
- (4) Pseudocoelomate – Arthropods ✗

2

Question no. 97

From the given characters, identify the uncommon character between cartilaginous and bony fish.

- (1) Two-chambered heart ✓
- (2) Sexes are separate ✓
- (3) They are cold-blooded animals ✓
- (4) Body is covered with placoid scales.

Right

4

Placoid scales only in Cartilaginous Fish.

Question no. 98

The paired mouth parts of cockroach are

- (1) Labrum and labium
- (2) Maxilla and mandible
- (3) Labium and hypopharynx
- (4) Labrum and maxilla

2

Question no. 99

Special venous connection between liver and intestine as well as the kidney and lower parts of body are present in frog that is called

- (1) Hepatic portal system
- (2) Renal portal system
- (3) Hepatic portal system and renal portal system, respectively
- (4) Renal portal system and hepatic portal system respectively

3

Portal circulation.

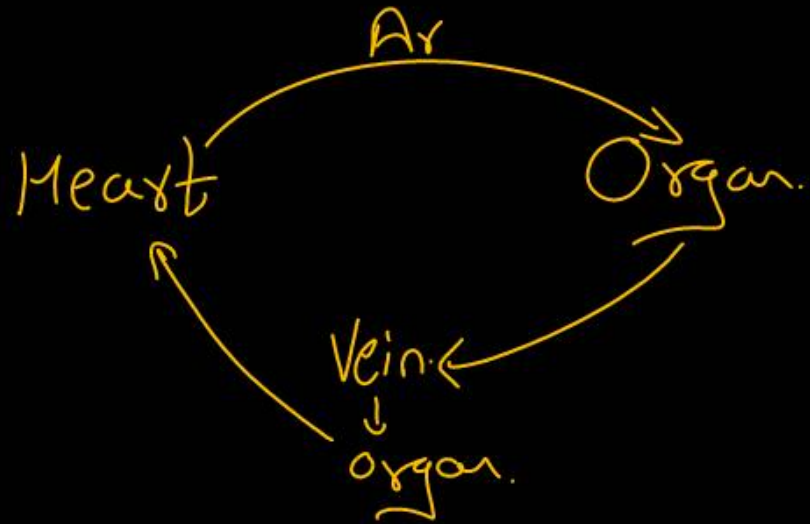
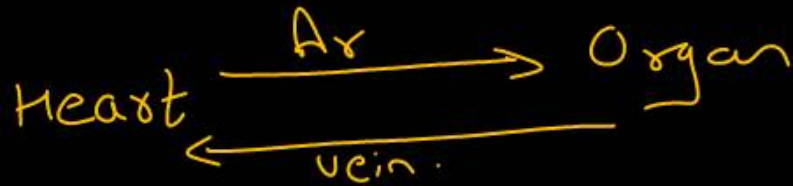

Question no. 100

Mark the option that is essentially a part of medullary pyramid.

- (1) PCT
- (2) DCT
- (3) Bowman's capsule
- (4) Loop of Henle

4

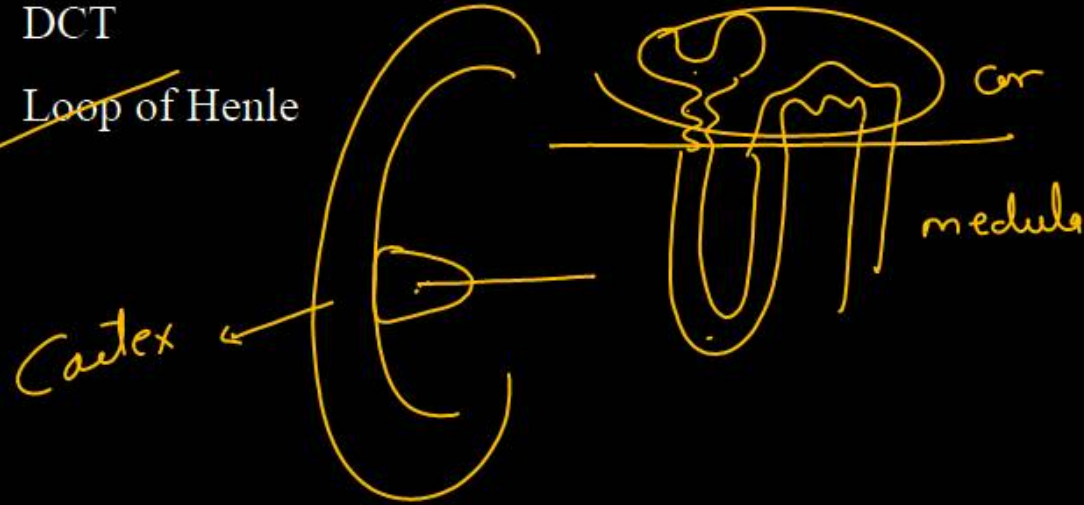

Question no. 101

In Which of the following disease, the antibodies are produced against neuromuscular junction?

Autoimmune disease

(1) Gout ✗

(2) Rheumatoid arthritis ✗

(3) Muscular dystrophy ✗

(4) Myasthenia gravis ✓

4

Question no. 102

The maximum reabsorption of useful substances back into the blood from filtrate in a nephron occurs in

- (1) PCT ✓
- (2) Loop of Henle
- (3) DCT
- (4) Collecting duct



Question no. 103

Match the items given in Column I with those in Column II and select the correct option given below:

	Column I		Column II
A.	Glycosuria	i.	Accumulation of <u>uric acid in joints</u>
B.	Gout	ii.	Mass of crystallised salts within the kidney
C.	Renal calculi	iii.	<u>Inflammation</u> in glomeruli
D.	<u>Glomerular nephritis</u>	iv.	Presence of glucose in urine

A B C D

A B C D

(1) ~~iii~~ ii iv i

(2) ~~i~~ ii iii iv

(3) iv ~~i~~ ii iii

(4) ~~ii~~ iii i iv

A - iv
B - i
C - ii
D - iii

3

Question no. 104

Two main sites of tubular secretion in nephron are

- (1) ~~PCT~~ and ~~Henle's loop~~
- (2) ~~Henle's loop~~ and DCT
- (3) ~~DCT~~ and ~~collecting duct~~
- (4) ~~PCT~~ and DCT

4

Question no. 105

Match column – I with column –II and select the correct option from the codes given below.

	Column I		Column II
A.	Structural and functional unit of a myofibril	I.	H-zone
B.	Protein of thin filament	II.	Myosin
C.	Protein of thick filament	III.	Sarcomere
D.	The central part of thick filament not overlapped by thin filament	IV.	Actin

- (1) A-I, B-II, C-III, D-IV
- (2) A-I, B-III, C-II, D-IV
- (3) A-I, B-IV, C-III, D-II
- (4) ~~A-III, B-IV, C-II, D-I~~

A-iii
B-iv
C-ii
D-i

4

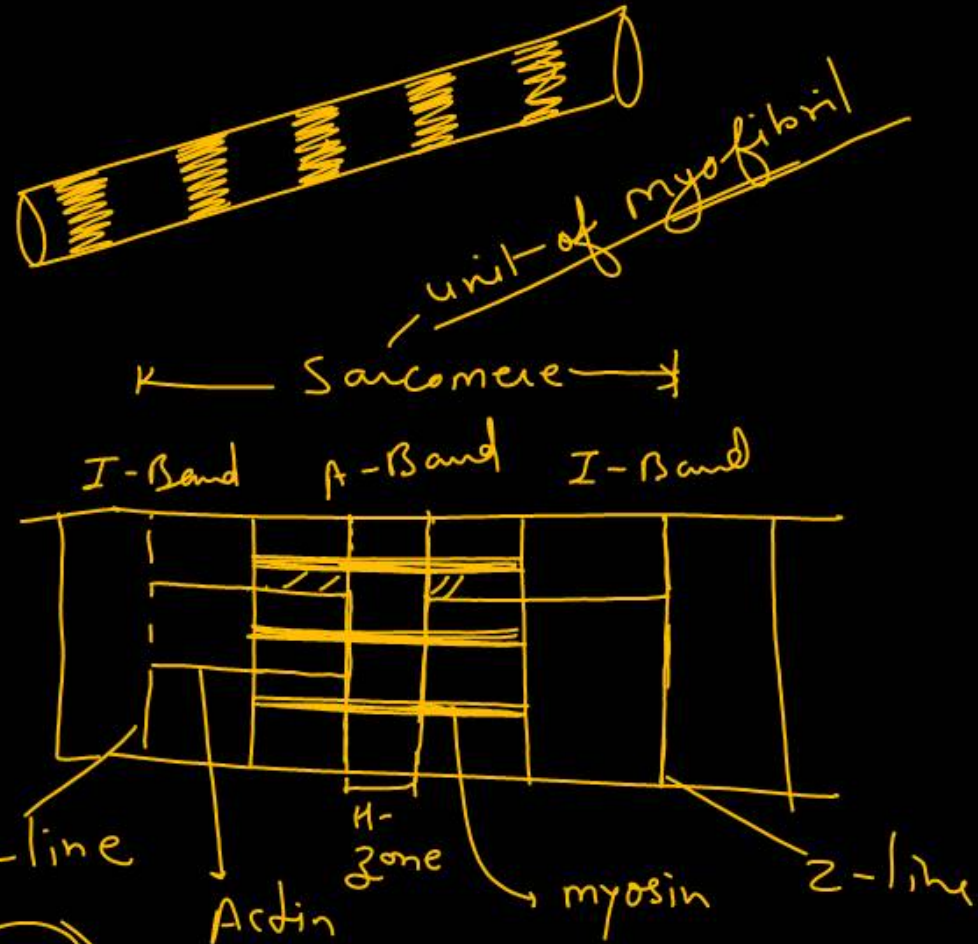

Question no. 106

The sliding filament theory can be best explained as:

- (1) When myofilaments slide pass each other Actin filaments shorten while myosin filament do not shorten
- (2) Actin and Myosin filaments shorten and slide pass each other
- (3) Actin and Myosin filaments do not shorten but rather slide pass each other
- (4) When myofilaments slide pass each other, Myosin filaments shorten while Actin filaments do not shorten

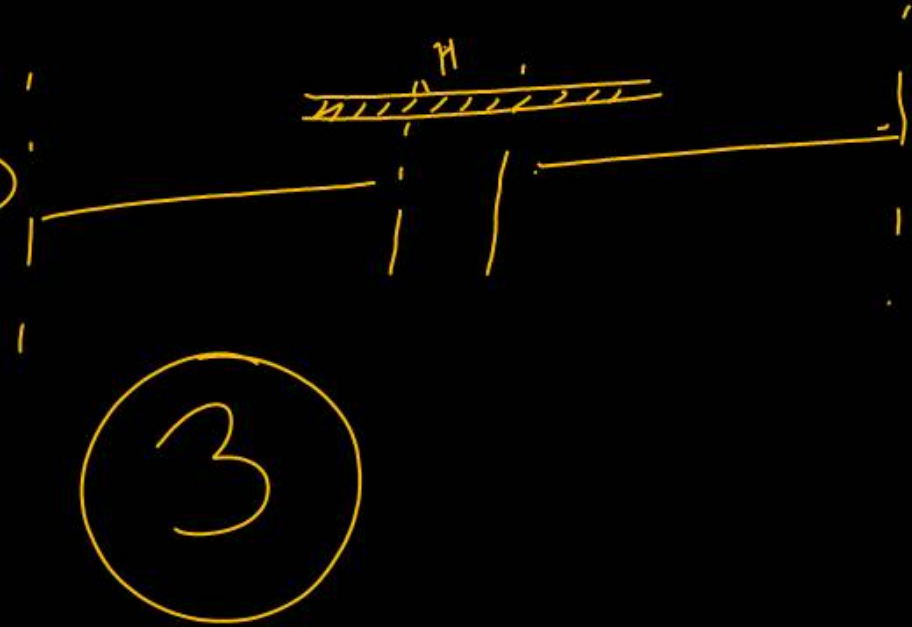

Question no. 107

Which of the following is ~~not~~ the feature of red muscle fibres

- (1) They have plenty of mitochondria
- (2) They have high content of Myoglobin ✓
- (3) ✓ They have high amount of Sarcoplasmic reticulum
- (4) They are called aerobic muscles.

3

Question no. 108

If the amount of DNA sample isolated is low, then which process is used for the amplification of DNA?

- (1) PCR technique
- (2) DNA microarrays
- (3) DNA electrophoresis
- (4) Southern blot techniques

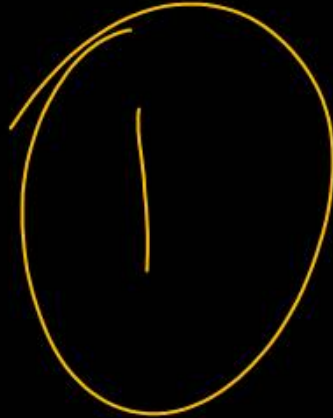

Question no. 109

During spermatogenesis the first meiotic division is observed in

- (1) Sertoli cells
- (2) Spermatids
- (3) Spermatozoans
- (4) Primary spermatocytes ✓

(n)

Primary spermatocyte
↓
1st meiotic division
↓
2^o spermatocyte

Question no. 110

Examples of vestigial organs in the human body are :

(1) ~~wisdom tooth, coccyx, vermiform appendix, nail~~

(2) ~~coccyx, wisdom tooth, vermiform appendix,~~
auricular muscles

(3) ~~coccyx, vermiform appendix, wisdom tooth,~~
~~pancreas~~

(4) ~~auricular muscles, coccyx, nail, wisdom tooth~~

2

Question no. 111

Which of the following is not a characteristic unique to all members of phylum chordata?

- (1) A notochord a dorsal hollow nerve cord
- (2) A ventral heart
- (3) An endoskeleton
- (4) Vertebral column ✓

4

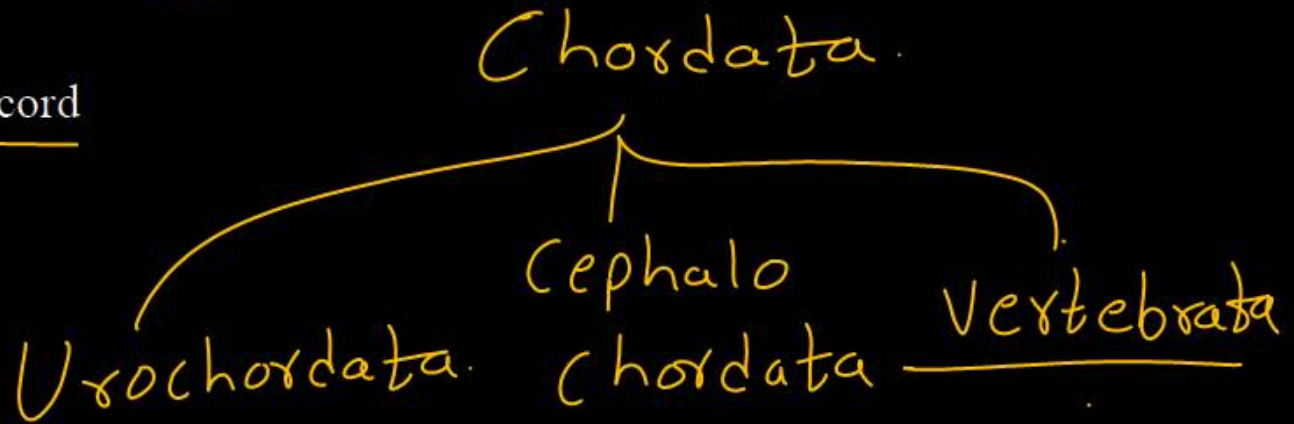

Question no. 112

Which of the following characteristic features always holds true for the corresponding group of animals?

(1) Cartilaginous endoskeleton - Chondrichthyes ✓

(2) Viviparous - Mammalia X ex ✓

(3) Possess a mouth with an upper and a lower jaw
- Chordata

(4) 3 - chambered heart with one incompletely divided ventricle - Reptilia

ex. cyclostomata

ex crocodile



Question no. 113

Toothed shaped scales are -

- (1) Cycloid (2) Ctenoid
(3) Genoid (4) Placoid

Fishes

4

Cartilaginous = Placoid

Bony = Cycloid / Ctenoid

Question no. 114

Chief producers of oceans are

- (1) Dinoflagellates ~~(2) Diatoms~~
(3) Protozoan protists (4) Blue green algae

2

Match the following and select the correct option.

	Column-I		Column-II
a.	Alternaria	i. →	Phycomycetes
b.	Mucor	ii. →	Ascomycetes
c.	Agaricus	iii. →	Deuteromycetes
d.	Claviceps	iv. →	Basidiomycetes

- (1) a-(iii), b-(iv), c-(ii), d-(i)
- (2) a-(i), b-(ii), c-(iv), d-(iii)
- ~~(3) a-(iii), b-(i), c-(iv), d-(ii)~~
- (4) a-(ii), b-(iii), c-(iv), d-(i)

3

Question no. 116

Mark the incorrect match with respect to taxonomic categories of Mango:

~~(1) Phylum – Gymnosperms~~

Angio.

(2) Order – Sapindales

(3) Family – Anacardiaceae

(4) Genus – Mangifera

①

Question no. 117

Dikaryon phase of fungus occurs in

- (1) Ascomycetes and Basidiomycetes
- (2) Phycomycetes and Ascomycetes
- (3) Phycomycetes and Basidiomycetes
- (4) Basidiomycetes and Deuteromycetes

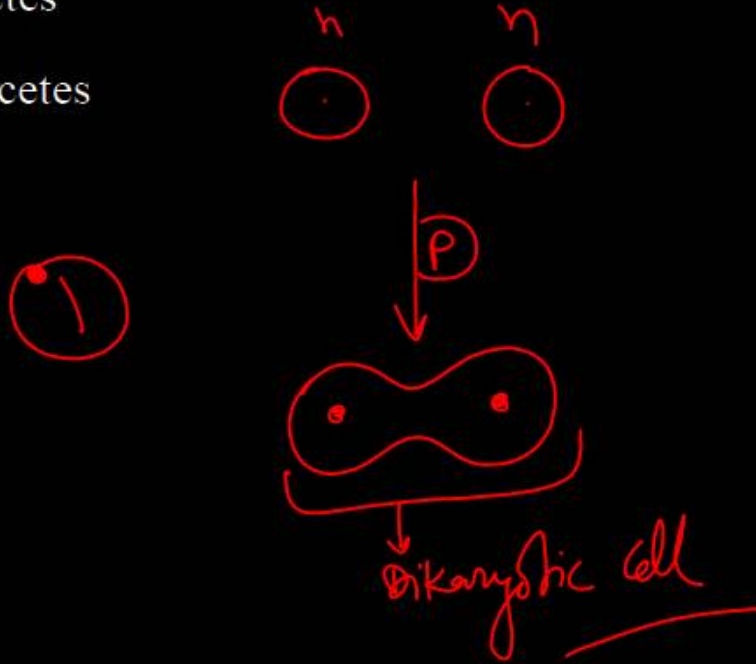

Question no. 118

The concept of contagium vivum fluidum (Infectious living fluid) for virus was given by -

- (1) Mayer ~~(2) Beijerinck~~
(3) Pasteur (4) Ivanowsky

2

Question no. 119

Mark the coelenterate that shows metagenesis.

(1) Hydra

(2) Adamsia

(3) Obelia ✓

(4) Gorgonia

Alternation of Generation.

Obelia
3

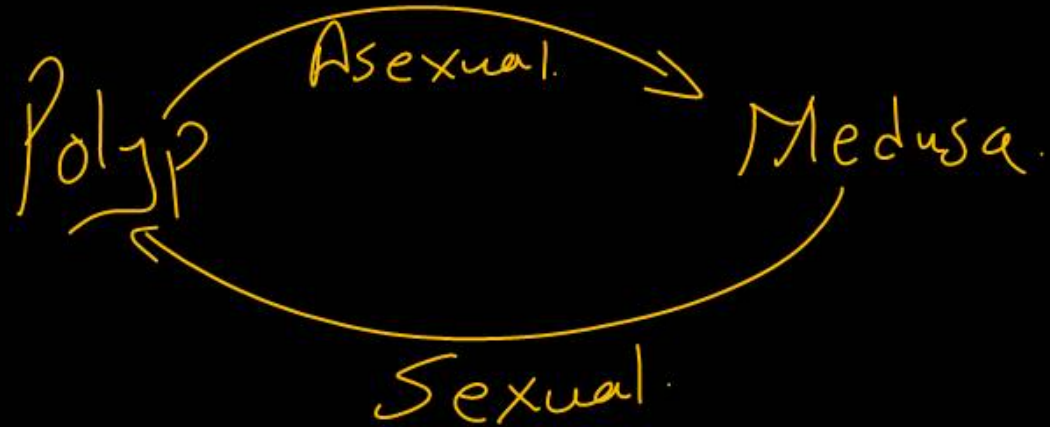

Question no. 120

Which of the following features is used to identify a male cockroach from a female cockroach?

- (1) Presence of a boat shaped sternum on the 9th abdominal segment.
- (2) Presence of caudal styles ✓
- (3) Forewings with darker tegmina
- (4) Presence of anal cerci

②

Male cockroach contain.
anal styles
Caudal

Question no. 121

In male cockroach, sperms are stored in

- (1) Vasa efferentia (2) Vas deferens
(3) Seminal vesicles (4) Phallic gland

3

Seminal vesicals
↳ Accessory gland
↳ Stores sperm.
↳ Nourishes sperm.

Question no. 122

Extension of cortex between medullary pyramids in kidney are known as

- (1) Renal calyces (2) Renal pelvis
(3) Columns of Bertini (4) Columns of Bellini

3

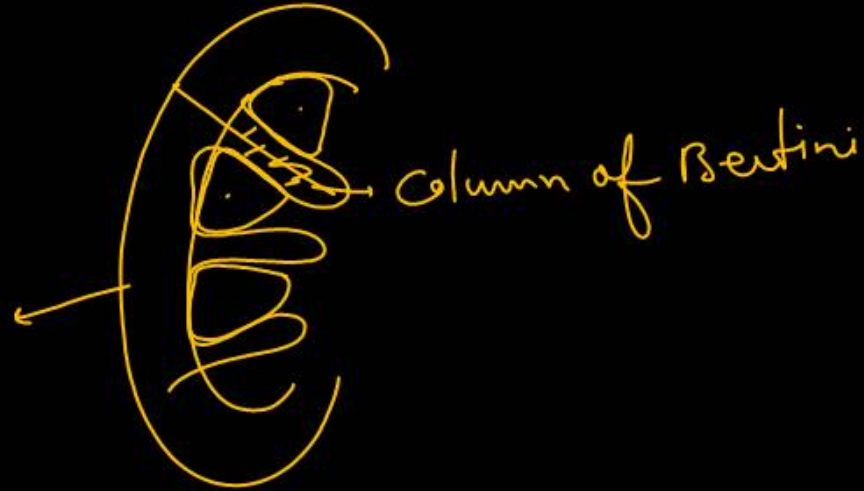

Question no. 123

Select the incorrect match between organism and its corresponding excretory structure.

(1) Nephridia – Earthworm ✓

(2) Flame cells – ~~Cockroach~~ ✓

(3) Antennal glands – Prawn ✓

(4) Protonephridia – Planaria ✓

platy

2

Question no. 124

In order to initiate muscle contraction, calcium ions bind to which one of the following?

- (1) ~~Tropomyosin~~ (2) Troponin
(3) Myosin head (4) Hensen's zone

2

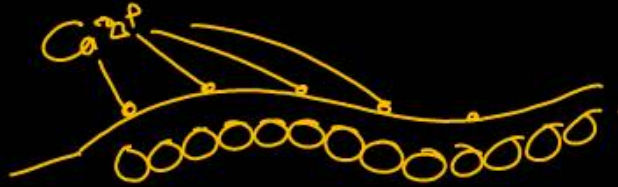

Question no. 125

Which of the following causes increase in sodium reabsorption in the distal convoluted tubule?

- (1) Increase in aldosterone level
- (2) Increase in antidiuretic hormone level
- (3) Decrease in aldosterone level
- (4) Decrease in antidiuretic hormone level

①

Adrenal
Cortex → Increased
Aldosterone level

D.C.T.

Reabsorption of Na^+

Question no. 126

H^+

Human urine is usually acidic because

- (1) excreted ~~plasma proteins~~ are acidic
- (2) ~~potassium and sodium~~ exchange generates acidity
- (3) ~~hydrogen ions~~ are actively secreted into the filtrate
- (4) the sodium transporter exchanges one hydrogen ion for each sodium ion, in peritubular capillaries

3

Question no. 127

Accessory excretory organs of man are

- (1) Only skin
- (2) Only skin and liver
- (3) Only skin and lungs
- (4) skin, lungs, and liver

Main excretory = kidney

✓
4

Question no. 128

Which statement is correct for muscle contraction?

- (1) Length of H-zone decreases ✓
- (2) Length of A-band remains constant ✓
- (3) Length of I-band increases ✗
- (4) Distance between two Z-lines increases ✗

① / ②

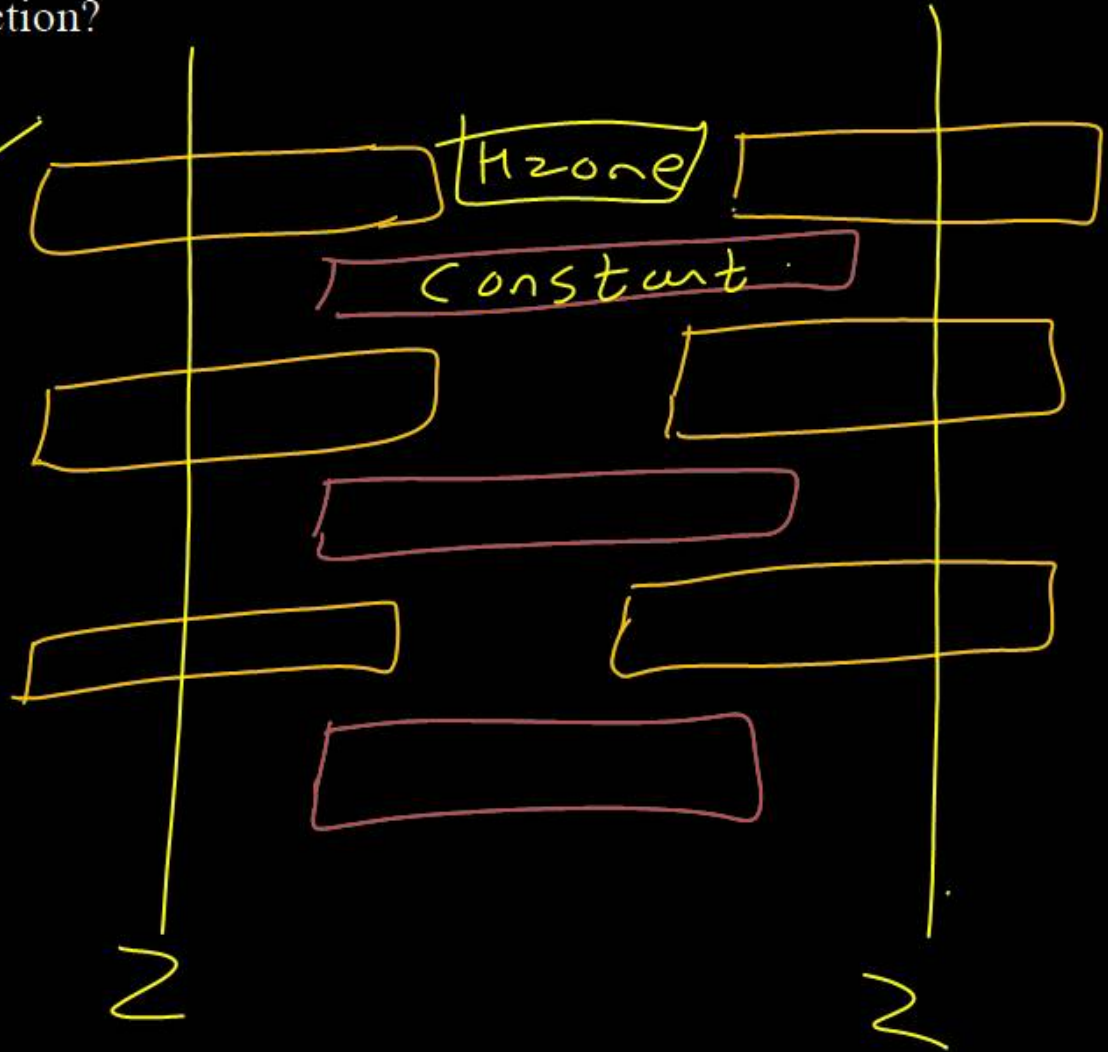

Question no. 129

Which of the following hormones can play a significant role in osteoporosis?

- (1) Aldosterone and ~~Prolactin~~
- (2) ~~Progesterone~~ and Aldosterone
- (3) Parathyroid hormone and ~~Prolactin~~
- (4) Estrogen and ~~Parathyroid hormone~~

Estrogen
PTH

4

Question no. 130

The H-zone in the skeletal muscle fibre is due to

- (1) The absence of myofibrils in the central portion of A – band
- (2) The central gap between myosin filaments in the A-band
- (3) The ~~central gap~~ between actin filaments extending throughout myosin filaments in the A-band
- (4) Extension of myosin filaments in the central portion

3

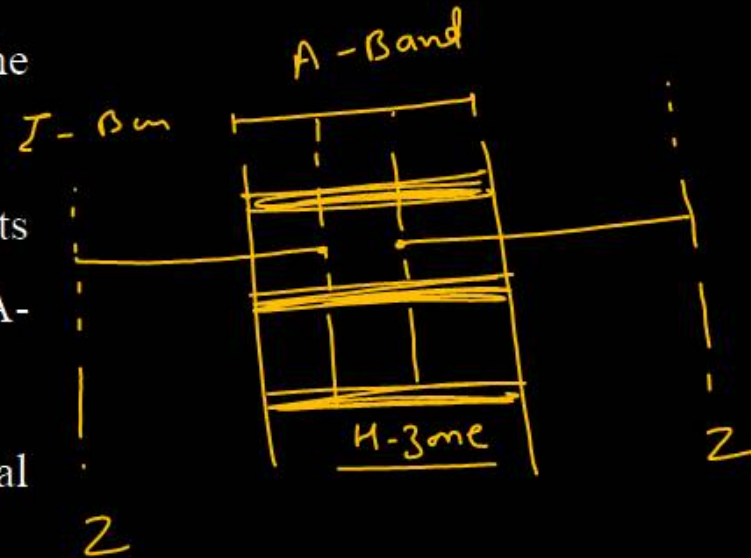

Question no. 131

Which of the following processes suggests the occurrence of convergent evolution?

- (1) Presence of vestigial organs
- (2) Presence of homologous structures
- (3) Presence of analogous structures
- (4) Reappearance of ancestral organs

3



Question no. 132

Immunity that develops in the fetus after receiving antibodies from mother's blood through placenta is

- (1) Naturally acquired active immunity ✗
- (2) Artificially acquired active immunity ✗
- (3) Naturally acquired passive immunity ✓
- (4) Artificially acquired passive immunity ✗

3

Question no. 133

Human Genome Project (HGP) was closely associated with the rapid development of a new area in biology called as

- (1) Biotechnology (2) Bioinformatics
(3) Biogeography (4) Bioscience

2

Question no. 134

Hemichordates have-

- (1) Open type of circulatory system ✓
- (2) Respiration by gill ✓
- (3) Proboscis gland/glomerulus as excretory organ
- (4) All ✓

4

Question no. 135

Match the following genera with their respective phylum:

Brittle Star

A.	Ophiura	i.	Mollusca
B.	Physalia	ii.	Platyhelminthes
C.	Pinctada	iii.	Echinodermata
D.	Planaria	iv.	Coelenterata

(1) A-iii, B-iv, C-ii, D-i (2) A-iv, B-i, C-iii, D-ii

~~(3) A-iii, B-iv, C-i, D-ii~~ (4) ~~A-i, B-iii, C-iv, D-ii~~

3

Question no. 136

Which one of the following correctly represents the manner of replication of DNA?

5' → 3'

(1)

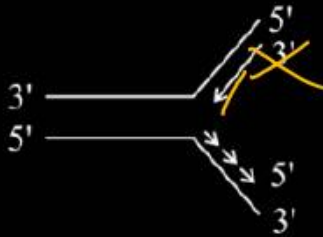

(2)

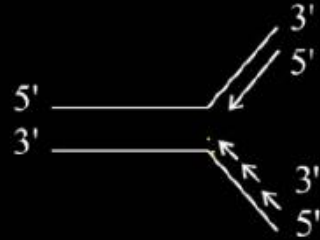

(3)

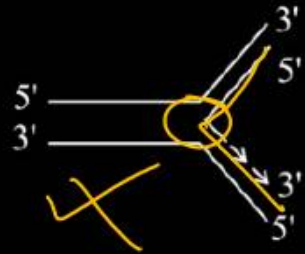

(4)

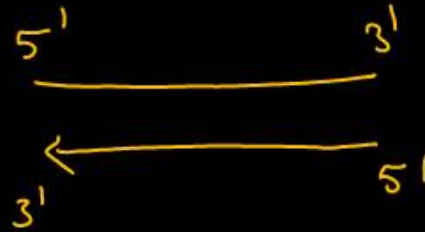
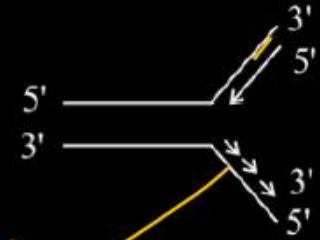

4

Question no. 137

A fungus that is found in aquatic habitats has aseptate and coenocytic mycelium and produces zoospores and aplanospores as asexual spores is put under the class

- (1) Phycomycetes (2) Ascomycetes
(3) Deuteromycetes (4) Basidiomycetes



Question no. 138

Which of the following is incorrect about Cyanobacteria?

- (1) They have chlorophyll a similar to green plants.
- (2) They are photoautotrophs.
- (3) They lack heterocysts.
- (4) They often form blooms in polluted water bodies.

3

Question no. 139

Which of the following is the correct sequence of taxonomic categories?

(1) Kingdom → Phylum → Class → ~~Family~~ →
Order → Genus → Species

~~(2)~~ Kingdom → Phylum → Class → Order →
Family → Genus → Species

(3) Phylum → Class → Family → Order → Species
→ Genus → Kingdom

2

(4) Phylum → Kingdom → Order → Family →
Class → Genus → Species

Question no. 140

In Whittaker's system of classification, prokaryotes belong to the kingdom

- ~~(1) Monera~~ (2) Protista
(3) Animalia (4) Fungi

①

Question no. 141

Which of the following statements is false about viruses

- (1) Viruses are obligate parasites ✓
- (2) Viruses can multiply only when they are inside the living cells / *Not* ✓
- ~~(3) Viruses cannot pass bacterial proof filters ✓~~
- (4) Viruses are made up of protein + DNA or RNA
(never both DNA and RNA) ✓

3

Question no. 142

Match the column I with column II and choose the correct combination from the options given below.

	Column-I		Column-II
a.	Porifera	i.	Canal system
b.	Aschelminthes	ii.	Water vascular system
c.	Annelida	iii.	Muscular Pharynx
d.	Arthropoda	iv.	Jointed appendage
e.	Echinodermata	v.	Metameres

1

- (1) a-(i), b-(iii), c-(v), d-(iv), e-(ii)
- (2) a-(ii), b-(iii), c-(v), d-(iv), e-(i)
- (3) a-(i), b-(v), c-(iii), d-(iv), e-(ii)
- (4) a-(ii), b-(v), c-(iii), d-(iv), e-(i)

Question no. 143

In cockroach, identify the parts of the foregut in correct sequence.

- (1) Mouth → Pharynx → Oesophagus → Crop → Gizzard
- (2) Mouth → Oesophagus → Pharynx → Crop → Gizzard
- (3) Mouth → Crop → Pharynx → Oesophagus → Gizzard
- (4) Mouth → Gizzard → Crop → Pharynx → Oesophagus

foregut

Fore
Mid.
Hind

1

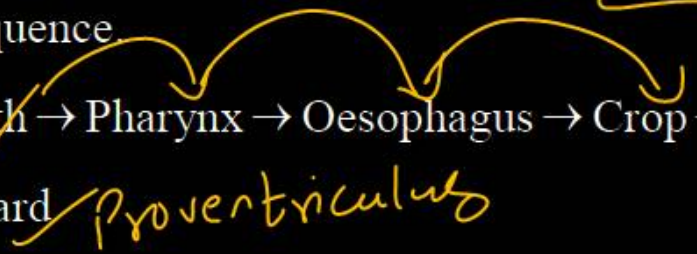

Question no. 144

The number of spiracles in cockroach are

- (1) 2 pairs on thorax and 6 pairs on the abdomen
- (2) 3 pairs on thorax and 7 pairs on the abdomen
- (3) ~~2 pairs~~ on thorax and 8 pairs on abdomen
- (4) 4 pairs on thorax and 6 pairs on abdomen

Spiracles
Small holes
openings

10 pairs
20

③ 2 pair - Thorax
8 pair - Abdomen

Question no. 145

Which of the following characteristics is shared by ammonia, urea and uric acid?

Nitrogenous waste

- (1) They are all equally toxic.
- (2) They all need very large amount of water for excretion.
- (3) They are all produced by kidneys.
- (4) They are all nitrogenous wastes.

4

Question no. 146

Dialysing unit (artificial kidney) contains a fluid which is almost same as plasma, except that it has

(1) High ~~urea~~

(2) No urea ✓

(3) Low glucose

(4) High glucose

2

Question no. 147

Which of the following set contains all groups of ureotelic animals?

- (1) Marine fishes, ~~terrestrial amphibians~~ and mammals
- (2) Bony fishes, ~~mammals~~ and terrestrial insects
- (3) Aquatic ~~insects~~, amphibians and land snails
- (4) Bony fishes, aquatic amphibians and terrestrial mammals

Urea

1

Question no. 148

- I. Excretory system absent.
- II. Dioecious, external fertilization, indirect development with free swimming larva
- III. Water vascular system is present
- IV. Unsegmented only
- V. Complete digestive system with ventral mouth and anus on dorsal or upper side

The above characters are associated with animals of -

- (1) Mollusca
- (2) Hemichordata
- (3) Echinodermata ✓
- (4) Annelida

3

Question no. 149

Which of the following parts of the nephron given in column I is correctly matched with their functions given in column II?

	Column I (Parts of the nephron)		Column II (Functions)
A.	Proximal convoluted tubules	I.	Sodium is reabsorbed
B.	Distal convoluted tubules	II.	Sodium and water are reabsorbed under the influence of hormone in this region
C.	Descending limb	III.	Primary site of glucose and amino acid reabsorption
D.	Ascending limb	IV.	Major substance reabsorbed here is water by osmosis.

- (1) A-I, B-II, C-III, D-IV
- (2) A-IV, B-I, C-II, D-III
- (3) A-III, ~~B-I~~, C-II, D-I
- (4) A-III, B-II, C-IV, D-I

A - iii
B - ii
C - iv
D - i

4

Question no. 150

The macrophages in human body exhibit

- (1) Ciliary movement
- (2) Amoeboid movement
- (3) No movement
- (4) Movement with the blood flow only

2

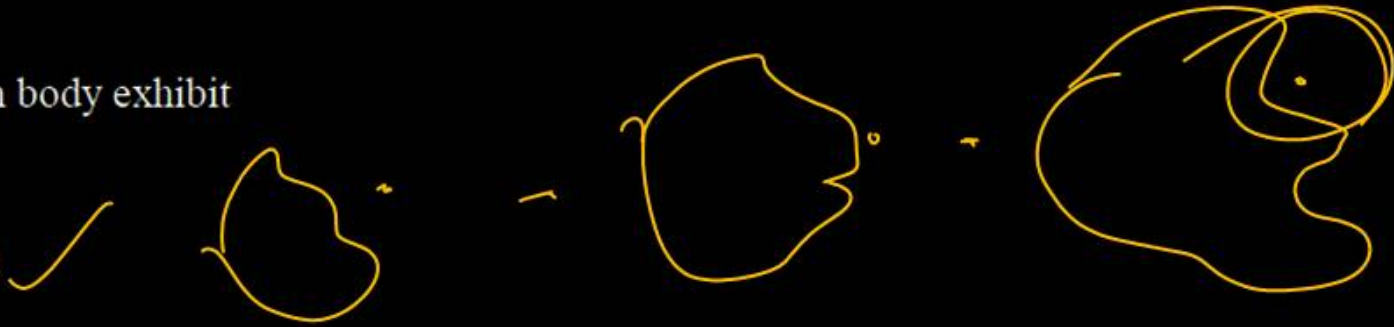

Question no. 151

Which of the following joints would allow no movement?

- (1) Cartilaginous joint ✓ (2) Synovial joint ✓
(3) Ball and socket joint (4) Fibrous joint

4

Question no. 152

Sarcomere is distance between

- (1) Two I-bands
- (2) A and I bands
- (3) Two Z-lines
- (4) Z and A bands

3

Question no. 153

Which one of the following is a chromosomal disorder

- (1) Haemophilia (2) Down's syndrome
(3) Phenylketonuria (4) Sickle-cell anaemia

2

Question no. 154

Widal test detects the presence of antibodies against which pathogen?

- (1) Vibrio cholera (2) Paramyxovirus
(3) Salmonella typhi (4) Influenza virus

3

Question no. 155

Which option provides correct sequence of events in origin of species according to Darwinism?

- A. Natural selection
- B. ~~Variations~~ and their inheritance
- C. Survival of fittest ✓
- D. ~~Struggle for existence~~

- (1) A, B, C, D
- (2) B, D, C, A
- (3) D, B, C, A
- (4) B, C, A, D

D → B → C → A

3

Question no. 156

Correct sequence of hormone secretion from beginning of menstruation is –

- (1) FSH, ~~progesterone~~, ~~estrogen~~
- (2) Estrogen, ~~FSH~~, progesterone
- (3) FSH, estrogen, progesterone ✓
- (4) Estrogen, progesterone, FSH

3

Question no. 157

Match the column and choose the correct option.

	Column I		Column II
A.	Cartilaginous fishes	I.	Usually external fertilization
B.	Bony fishes	II.	Internal fertilization
		III.	Mostly oviparous
		IV.	Many are viviparous
		V.	Direct development

2

- (1) A-I, III, V B-I, II
(2) ✓ A-II, IV B-I, III, V
(3) A-III, V B-I, II, IV
(4) A-I, II, IV B-III, IV

Question no. 158

Which one is the oviparous mammal?

- (1) Macropus (Kangaroo)
- (2) Panthera
- (3) Ornithoryhynchus (Platypus)
- (4) Whale

③

3rd option is correct.

egg laying

Question no. 159

Deuteromycetes is called 'fungi imperfecti' because of

- (1) Absence of conenocytic mycelium
- ~~(2) Absence of sexual stage~~
- (3) Presence of secondary mycelium
- (4) Absence of saprophytic forms

2

Question no. 160

The set of rules and recommendations dealing with the formal names of plants is given by

(1) ICZN

(2) ICBN

(3) ICNB

(4) ICNCP

Botanical
↓
Plants

2

Question no. 161

Which of the following is an example of amoeboid protozoans?

(1) Trypanosoma → fl.

(2) Paramecium Ciliated.

(3) Gonyaulax

~~(4) Entamoeba~~

→ Red Dino.

4

Question no. 162

Viruses are non-cellular organisms but replicate themselves once they infect the host cell. To which of the following kingdom viruses belong to?

(1) ~~Monera~~

(2) ~~Protista~~

(3) ~~Fungi~~

(4) ~~None of these~~

4

Question no. 163

The genetic material for most of the bacteriophages is-

(1) ssRNA

(2) dsRNA

(3) dsDNA

(4) ssDNA

3

Question no. 164

The mouth of molluscs has a file-like rasping organ called

- (1) Ommatida
- (2) Ommatophore
- (3) Radula
- (4) Clome

feeding



Question no. 165

In cockroach structure related with excretion are

- A. Phallic gland ✓
- B. Urecose gland
- C. Nephrocytes
- D. Fat body
- E. Collateral glands ✓

Choose the correct answer from the options given below.

- (1) A, B and E only
- (2) ✓ B, C and D only
- (3) B and D only
- (4) A and E only

2

Question no. 166

In frog, the duodenum receives bile from gall bladder and pancreatic juices from the pancreas through a

- (1) Common bile duct ✓
- (2) Hepato – pancreatic duct
- (3) Cystic duct
- (4) Hepatic duct

1

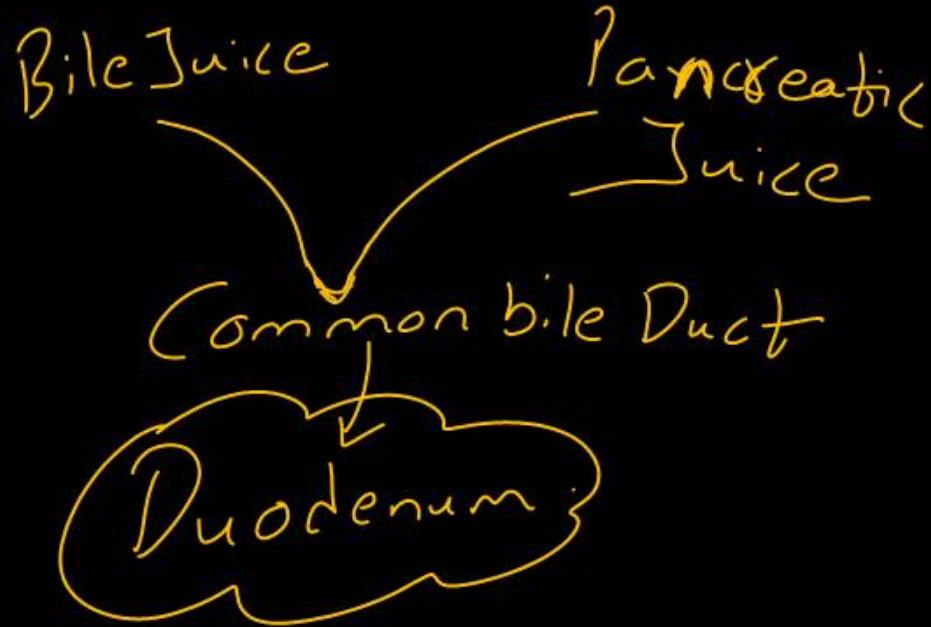

Question no. 167

Juxtamedullary nephron differs from cortical nephron

in

- A. Number ✓
- B. Presence of vasa recta ✓
- C. Length of loop of Henle ✓

- (1) A and B only
- (2) B and C only
- (3) A only
- (4) ✓ A, B and C

4

J.M.N
15%
Present
Long

C.N.
85%
Absent
Short

Question no. 168

Match column I with column II and choose the correct combination from the options given below.

	Column-I		Column-II
a.	Ball and socket joint	i.	Humerus and pectoral girdle
b.	Hinge joint	ii.	Knee joint
c.	Fibrous joint	iii.	Sutures of cranium
d.	Saddle joint	iv.	Carpal and metacarpal of thumb



(1) a-(i), b-(ii), c-(iii), d-(iv)

(2) ~~a-(ii), b-(iii), c-(i), d-(iv)~~

(3) ~~a-(iv), b-(iii), c-(ii), d-(i)~~

(4) a-(i), b-(iv), c-(iii), d-(ii)

Question no. 169

The concentration of glomerular filtrate is the maximum at:

- (1) Proximal part of Henle's loop
- (2) Proximal convoluted tubule
- (3) Ascending limb of Henle
- (4) U-shaped turn of Henle's loop

(4)

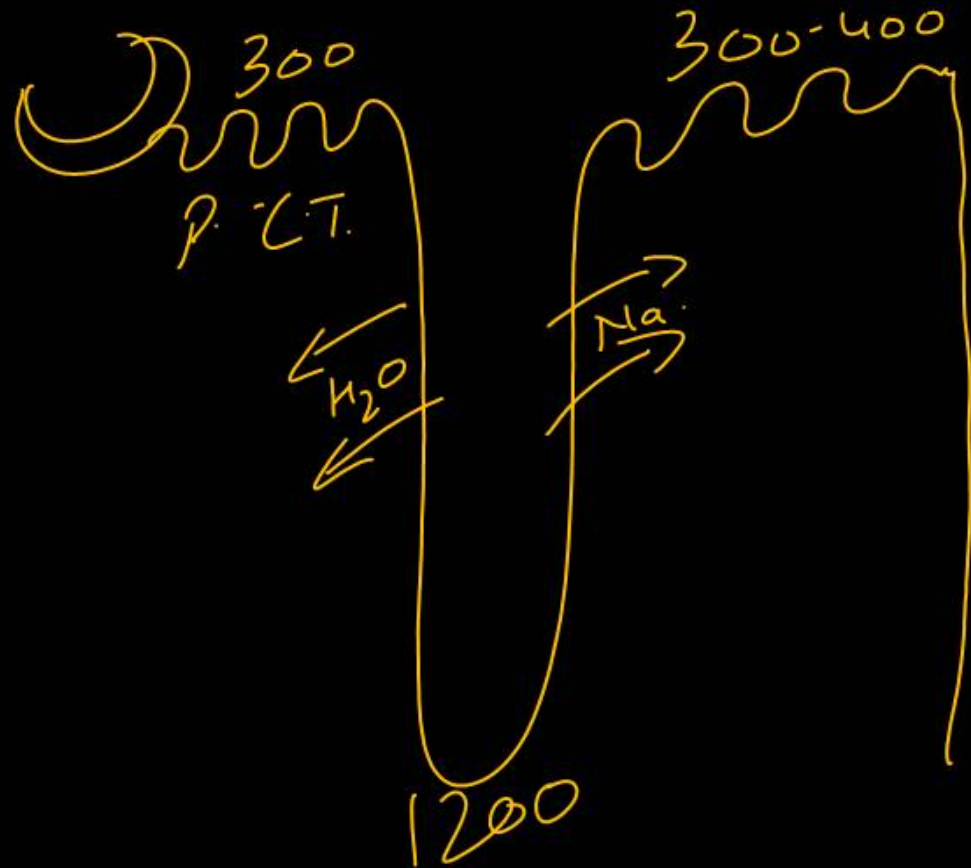

Question no. 170

Given below are two statements :

Assertion (A) : Ascending limb of loop of Henle is impermeable to water and allows transport of electrolytes actively or passively.

Reason (R) : Dilution of filtrate takes place due to efflux of electrolytes in the medullary fluid.

- (1) Both (A) and (R) are true and (R) is the correct explanation of (A)
- (2) Both (A) and (R) are true but (R) is not the correct explanation of (A)
- (3) (A) is true but (R) is false
- (4) (A) is false but (R) is true



Question no. 171

Shark, Torpedo (Electric ray) and Trygon (Sting ray)
belongs to –

- (1) Cyclostomata (2) Chondrichthyes
(3) Osteichthyes (4) Amphibia

2

Question no. 172

An acromian process is characteristically found in the:

- (1) ~~Pelvic girdle of mammals~~
- (2) Pectoral girdle of mammals
- (3) Skull of frog
- (4) Sperm of mammals

2

Question no. 173

Select the correct statement regarding the specific disorder of muscular or skeletal system:

- (1) Myasthenia gravis – Auto immune disorder which ~~inhibits sliding of myosin filaments~~
- (2) Gout – inflammation of joints due to extra deposition of calcium.
- (3) Muscular dystrophy – age related shortening of muscles
- (4) Osteoporosis – decreases in bone density and increased chances of fracture with developing age.

4

Question no. 174

Read the following 4-statements (A–D) and accordingly mark the option that has both correct statements

- A. Cardiac muscle fibres are branched and striated. ✓
- B. Smooth muscles are unbranched and cylindrical. ✓ *spindle*
- C. Striated muscles can be branched or unbranched. ✓
- D. Involuntary muscles are non-striated. ✓

- (1) A and D
- (2) B and C
- (3) C and D
- (4) A and C

4

Question no. 175

'Cyclosporin A' used as an immuno suppressive agent in organ-transplant patient, is produced by

- (1) Trichoderma polysporum
- (2) Monascus purpureus
- (3) Streptococcus
- (4) Aspergillus niger



Question no. 176

Which of the following is wrongly matched?

- (1) IUI – Semen collected from husband or donor is artificially introduced either into the vagina or into the uterus.
- (2) GIFT – Transfer of embryos with more than 8 blastomeres into the fallopian tube.
- (3) ICSI – Sperm directly injected into the ovum.
- (4) ZIFT – Transfer of embryos with upto 8 blastomeres into the fallopian tube.

φ (2)

Question no. 177

Match the bones of column A with their corresponding number in column B.

	Column A		Column B
A.	True ribs	i.	14
B.	Cervical vertebrae	ii.	7
C.	Cranium bones	iii.	8
D.	Vertebrochondral ribs	iv.	6

- (1) A – ii; B – iii; C – i; D – iv
(2) ~~A – i; B – ii; C – iii; D – iv~~
(3) A – ii; B – iii; C – iv; D – i
(4) A – i; B – iii; C – ii; D – iv

2

Question no. 178

Identify the incorrect statements.

(i) Reabsorption of water occurs passively in the initial segment of nephron. ✓

(ii) Nitrogenous waste are absorbed by active transport. ✗

(iii) conditional reabsorption of Na^+ and water takes place in DCT. ✓

(iv) DCT reabsorbs glucose. ✗

(v) DCT is capable of selective secretion of H^+ , K^+ and NH_3 to maintain pH and Na^+ K^+ , balance in blood. ✓

(1) (i) and (ii)

(2) (iii) and (iv)

(3) (iv) and (v)

✓ (4) (ii) and (iv)

4

Question no. 179

All are cold blooded animals except-

(1) Fishes, Amphibia, reptiles

(2) Birds and Mammals

(3) Only mammals

(4) Only birds

2

Warm
Blooded

Question no. 180

The ascending loop of Henle is permeable for

- (1) Ammonia
- (2) Glucose
- (3) Sodium
- (4) Water

3

